



## Stand-on Floor Scale

USER MANUAL

**MS3400-1**

















Please keep the instruction manual at hand and follow instruction for use.

# CONTENTS

<b>I. Explanation of Graphic Symbols on Label/Packaging .....</b>	<b>3</b>
<b>II. Copyright Notice.....</b>	<b>5</b>
<b>III. Safety Notes .....</b>	<b>6</b>
A. General Information.....	6
B. EMC Guidance and Manufacturer's Declaration .....	10
<b>IV. Installation .....</b>	<b>10</b>
A. Assembly .....	14
B. Replacing Batteries .....	17
C. Using Adapter .....	19
D. Attaching Height Rod to Column .....	20
E. Using HM201M Height Rod .....	21
<b>V. Indicator .....</b>	<b>23</b>
A. Indicator and Key Functions .....	23
<b>VI. Using Device .....</b>	<b>24</b>
A. Basic Operation .....	24
B. Hold .....	24
C. BMI .....	25
D. Tare.....	25
<b>VII. Device Setup .....</b>	<b>26</b>
<b>VIII. Troubleshooting.....</b>	<b>27</b>
<b>IX. Product Specifications .....</b>	<b>30</b>
A. Device Information .....	30
B. Power Adapter Standards.....	31
C. Standard Parts .....	32
<b>X. Declaration of Conformity .....</b>	<b>33</b>

# I.Explanation of Graphic Symbols on Label/Packaging

Text/Symbol	Meaning
	Caution, consult accompanying documents before use
	Separate collection for waste of electrical and electronic equipment, in accordance with Directive 2002/96/EC. Do not dispose of device with everyday waste
	Name and address of device manufacturer, and year/country of manufacture
	Carefully read user manual before installation and usage, and follow instructions for use.
	Medical electrical device, Type B applied part
	Medical electrical device, Type BF applied part
	Device catalogue number / model number
	Name and address of authorized representative in the European Union
	Device is a medical device. Text indicates device category type
	Manufacturer's batch or lot number for device
	Device's serial number
	Device's Unique Device Identifier
	Verification Scale Interval. Value expressed in units of mass. Used to classification and verification of an instrument.
	Device conforms to (EU) 2017/745 Regulation on Medical Devices. Fourdigit number is identifier for medical device Notified Body

Device complies with EC directives (verified models only)

CE M 20 0122

**M**: Conformity label in compliance with Directive 2014/31/EU for non-automatic weighing instruments

**20**: Year in which conformity verification was performed and the CE label was applied. (ex: 16=2016)

**0122**: Identifier for metrology Notified Body

---



Device is a Class III scale in compliance with Directive 2014/31/EU (verified models only)

---



Name and address of entity importing device (if applicable)

---



Name and address of entity responsible for translating Information For Use (if applicable)

---

CON.

Event counter confirming how many times device has been calibrated (if applicable)

---



Device conforms to Taiwan National Communications Commission(NCC) approval

---



Device conforms to U.S. Federal Communications Commission regulations

---

UK CA M 20 8506

Device complies with UK non-automatic weighing instruments regulations 2016 (verified models only)

**M**: Conformity label in compliance with Non-automatic Weighing instruments Regulations 2016

**20**: Year in which conformity verification was performed and the UKCA label was applied. (ex: 20=2020)

**8506**: Identifier for metrology approved body

---



Device complies with all UK applicable product legislation

---



Device's polarity of power.

---

**"In case of differences, icon on device itself takes precedence"**

## II. Copyright Notice

### Copyright Notice

#### **Charder Electronic Co., Ltd.**

No.103, Guozhong Rd., Dali Dist., Taichung City41262Taiwan

Tel: +886-4-2406 3766

Fax: +886-4-2406 5612

Website: [www.chardermedical.com](http://www.chardermedical.com) E-mail: [info\\_cec@charder.com.tw](mailto:info_cec@charder.com.tw)

Copyright© Charder Electronic Co., Ltd. All rights reserved.

This user manual is protected by international copyright law. All content is licensed, and usage is subject to written authorization from Charder Electronic Co., Ltd. (hereinafter Charder) Charder is not liable for any damage caused by a failure to adhere to requirements stated in this manual. Charder reserves the right to correct misprints in the manual without prior notice, and modify the exterior of the device for quality purposes without customer consent.



Charder Electronic Co., Ltd.  
No. 103, Guozhong Rd., Dali Dist.,  
Taichung City, 41262 Taiwan

## III. Safety Notes

### A. General Information

Thank you for choosing this Charder Medical device. It is designed to be easy and straightforward to operate, but if you encounter any problems not addressed in this manual, please contact your local Charder service partner.

Before beginning operation of the device, please read this user manual carefully, and keep it in a safe place for reference. It contains important instructions regarding installation, proper usage, and maintenance.

#### **Intended Purpose**

This medical device is designed to be used in accordance with national regulations, to measure weight within specifications, for weight-related usage by professionals.

#### **Clinical Benefit**

Measurement results can be used by professionals to diagnose (and monitor) weight-related issues.

#### **Intended medical indications/contraindications**

Measurement: patient's body weight. No known contraindications to measurement of body weight.

#### **Intended patient profile**

- (a) Age: no restrictions
- (b) Weight: no restrictions within device weight capacity
- (c) Patient Conditions: require measurement of body weight. Able to stand independently without support.

#### **Intended user profile**

- (a) At least 20 years old
- (b) Minimum knowledge:
  - To be able to read at a high-school level and understand Arabic numerals (e.g. 1, 2, 3, 4...)
  - Basic hygiene knowledge
  - Trained in device's operation

- Read the instruction manual
- (c) Language
  - Able to read the language of instruction manual and on-screen instructions
- (d) Qualifications
  - No special certifications or qualifications required

### **Residual Risk Evaluation**

- (a) All foreseeable risks have been evaluated and considered acceptable. Generally speaking, the most likely risk caused by incorrect usage of the device is less accurate measurement (or inability to use device to acquire measurement), which does not pose imminent physical risk to patient or user.
- (b) Benefit-risk ratio is considered acceptable. Stand-on floor scales are an important option for measuring patients. Usage of device is unlikely to result in harm to user or patient.

### **General Handling**

- Device should be placed on stable, flat, solid, non-slippery surface.
- Usage on soft surfaces (ex: carpet) may result in inaccurate results.
- Ensure all parts are properly locked and tightened before operating the device.

### **Safety Instructions**

Before putting device into use, please read this user manual carefully. It contains important instructions for installation, usage, and maintenance of device.

The manufacturer shall not be liable for damages caused by failure to heed the following instructions:

- Batteries should be kept away from children. If swallowed, promptly seek medical assistance.
- Expected service life: 5 years.
- Always comply with appropriate regulations when using electrical components under increased safety requirements.
- Improper installation will render the warranty null and void.
- Ensure voltage marked on power supply matches mains power supply.
- The device is intended for indoor use only.
- Observe permissible ambient temperatures for use
- Device meets requirements for electromagnetic compatibility. Do not exceed the maximum values specified in the applicable standards.

## **Environmental**

- All batteries contain toxic compounds; batteries should be disposed of via designated competent organizations. Batteries should not be incinerated.
- Device should be used within specified operating temperature. Although it will operate at higher and lower temperatures, accuracy may be adversely affected.

## **Cleaning**

- Device surface should be cleaned using alcohol-based wipes. Corrosive cleansing liquids should not be used. Pressure-washers should not be used.
- Do not use large amounts of water when cleaning the device, as it may cause damage to the internal electronics.
- Always disconnect device from mains power before cleaning.

## **Maintenance**

- Please contact your local Charder distributor for regular maintenance and calibration, regular checking of accuracy is recommended; frequency to be determined by level of use and state of device.

## **Warranty/Liability**

- If Charder is responsible for a fault or defect present upon receipt of the unit, Charder shall either repair the fault, or supply a replacement unit. Should the repairs or replacement delivery fail, statutory provisions shall be valid. The period of warranty shall be two years, beginning on the date of purchase. Please retain your receipt as proof of purchase.
- No responsibility shall be accepted for damage caused through any of the following reasons: unsuitable or improper storage or use, incorrect installation or commissioning by the owner or third parties, natural wear and tear, changes or modifications, incorrect or negligent handling, chemical, electrochemical, or electrical interference, unless damage is attributable to negligence on the part of Charder.
- This device does not contain any user-maintained parts. All maintenance, technical inspections, and repairs should be conducted by an authorized Charder service partner, using original Charder accessories and spare parts. Charder is not liable for any damages arising from improper maintenance or usage. Dismantlement of the device will void the warranty.



## **Disposal**

- This product is not to be treated as regular household waste, but should be taken to a designated collection points for electronics. Further information should be provided by local waste disposal authorities.



## **Warning**

- Only the original adapter should be used with the device. Using an adapter other than the one provided by Charder may cause malfunction.
- Do not touch the power supply with wet hands.
- Do not crimp the power cable, and avoid sharp edges.
- Do not overload extension cables connected to the device.
- Route cables carefully, to avoid tripping.
- Keep device away from liquids.
- Do not remove the plug by yanking on the cable.
- Use only a correctly wired (100-240VAC) outlet, and do not use a multiple outlet extension cable.
- Do not under any circumstances dismantle or alter the device, as this could result in electric shock or injury as well as adversely affect the precision of measurements.
- Do not place the device in direct sunlight, or in close proximity to an intense heat source. Excessively high temperatures may damage the internal electronics.

## **Incident Reporting**

- Any serious incident that has occurred in relation to the device should be reported to the manufacturer, EU representative (if device is used in EU member state), and competent authority of user/subject's member state.

## B. EMC Guidance and Manufacturer's Declaration

<b>Guidance and manufacturer's declaration-electromagnetic emissions</b>		
<p>The product is intended for use in the electromagnetic environment specified below. The customer or the user of the product should assure that it is used in such an environment.</p>		
<b>Emission test</b>	<b>Compliance</b>	<b>Electromagnetic environment-guidance</b>
RF emissions CISPR 11	Group 1	The product uses RF energy only for its internal function. Therefore, its RF emissions are very low and are not likely to cause any interference in nearby electronic equipment.
RF emissions CISPR 11	Class A	The product is suitable for use in all establishments other than domestic and those directly connected to a low voltage power supply network which supplies buildings used for domestic purposes.
Harmonic emissions IEC 61000-3-2	Class A	
Voltage fluctuations /flicker emissions IEC 61000-3-3	Compliance	

**Guidance and manufacturer's declaration-electromagnetic immunity**

The product is intended for use in the electromagnetic environment specified below. The customer or the user of the product should assure that it is used in such an environment.

Immunity test	IEC 60601 test level	Compliance level	Electromagnetic environment-guidance
Electrostatic discharge(ESD) IEC 61000-4-2	<u>± 8 kV contact</u> <u>± 2 kV, ± 4 kV, ± 8 kV, ± 15 kV air</u>	<u>± 8 kV contact</u> <u>± 2 kV, ± 4 kV, ± 8 kV, ± 15 kV air</u>	Floors should be wood, concrete or ceramic tile. If floors are covered with synthetic material, the relative humidity should be at least 30%
Electrical fast transient/burst IEC 61000-4-4	± 2kV for power supply lines	± 2kV for power supply lines	Mains power quality should be that of a typical commercial or hospital environment.
Surge IEC 61000-4-5	± 1kV line(s) to line(s) ± 2kV line(s) to earth	± 1kV line(s) to line(s) ± 2kV line(s) to earth	Mains power quality should be that of a typical commercial or hospital environment.
Voltage Dips, short interruptions and voltage variations on power supply input lines IEC 61000-4-11	<u>0% UT for 0.5 cycle</u> <u>0% UT for 1 cycle</u>  <u>70% UT(30% dip in UT) for 25cycles</u>  <u>0% UT for 5 s</u>	<u>0% UT for 0,5 cycle</u> <u>0% UT for 1 cycle</u>  <u>70% UT(30% dip in UT) for 25cycles</u>  <u>0% UT for 5 s</u>	Mains power quality should be that of a typical commercial or hospital environment. If the user of the product requires continued operation during power mains interruptions, it is recommended that the product be powered from an uninterruptible power supply or a battery.
Power frequency(50, 60 Hz) magnetic field IEC 61000-4-8	<u>30 A/m</u>	30 A/m	The product power frequency magnetic fields should be at levels characteristic of a typical location in a typical commercial or hospital environment.



- a Field strengths from fixed transmitters, such as base stations for radio (cellular/cordless) telephones and land mobile radios, amateur radio, AM and FM radio broadcast and TV broadcast cannot be predicted theoretically with accuracy. To assess the electromagnetic environment due to fixed RF transmitters, an electromagnetic site survey should be considered. If the measured field strength in the location in which the product is used exceeds the applicable RF compliance level above, the product should be observed to verify normal operation. If abnormal performance is observed, additional measures may be necessary, such as re-orienting or relocating the product.
- b Over the frequency range 150 kHz to 80 MHz, field strengths should be less than 3V/m.

**Recommended separation distance between portable and mobile RF communications equipment and the product**

The product is intended for use in an electromagnetic environment in which radiated RF disturbances are controlled. The customer or the user of the product can help prevent electromagnetic interference by maintaining a minimum distance between portable and mobile RF communications equipment (transmitters) and the product as recommended below, according to the maximum output power of the communications equipment.

Rated maximum output power of transmitter W	Separation distance according to frequency of transmitter m		
	150 kHz to 80 MHz $d = 1,2\sqrt{P}$	80 MHz to 800 MHz $d = 1,2\sqrt{P}$	<u>800 MHz to 2,7 GHz</u> $d = 2,3\sqrt{P}$
0,01	0,12	0,12	0,23
0,1	0,38	0,38	0,73
1	1,2	1,2	2,3
10	3,8	3,8	7,3
100	12	12	23

For transmitters rated at a maximum output power not listed above, the recommended separation distance d in metres (m) can be estimated using the equation applicable to the frequency of the transmitter, where p is the maximum output power rating of the transmitter in watts (W) according to the transmitter manufacturer.

NOTE1 At 80 MHz and 800 MHz, the separation distance for the higher frequency range applies.

NOTE2 These guidelines may not apply in all situations. Electromagnetic propagation is affected by absorption and reflection from structures, objects and people.

## IV. Installation

### A. Assembly

1. Insert column into column seat.

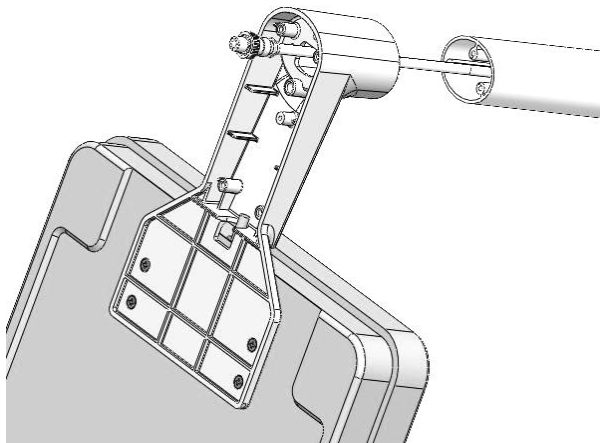

2. Insert and fasten 3 M4\*0.7\*15 screws at the bottom of the base

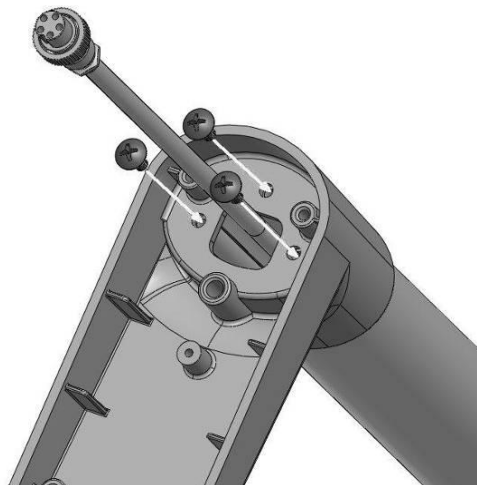

3.Route the cable along the gap in the column seat.

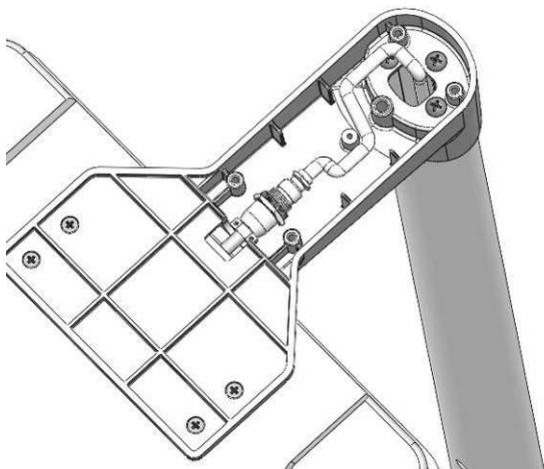

4. Place bottom cover in position. Insert and fasten four M4\*0.7\*8 screws.

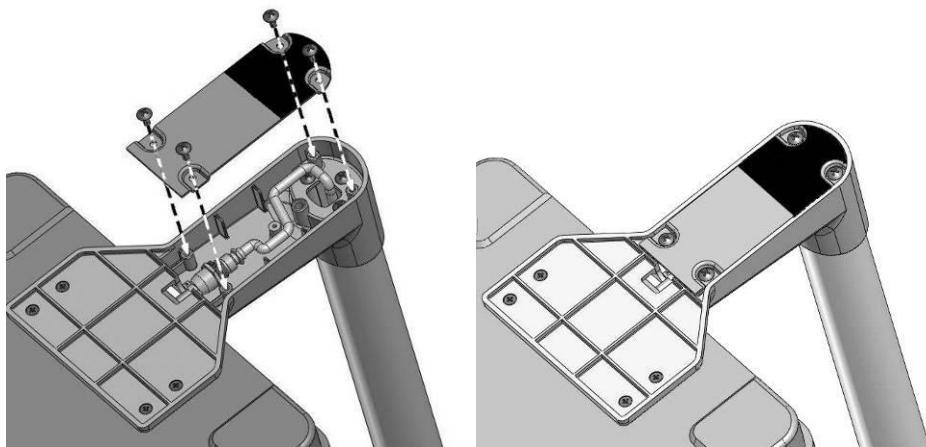

**Using wheel castor (optional)**

1. If installed on device, wheel castor is located behind column

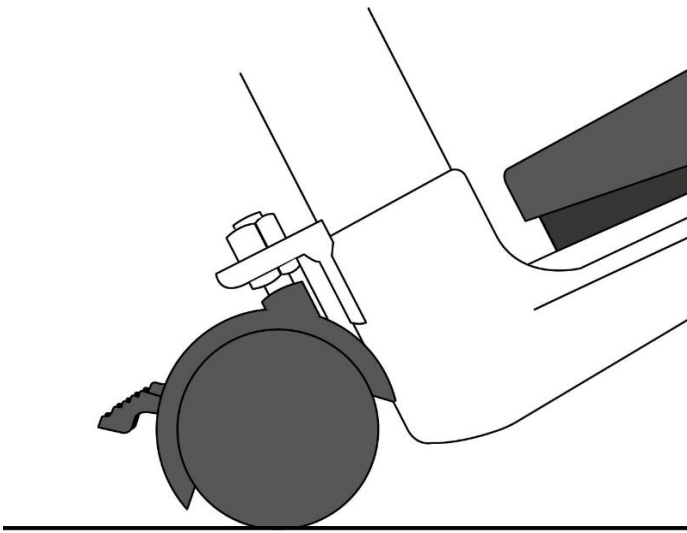

2. Press the brake down to lock the castor wheel

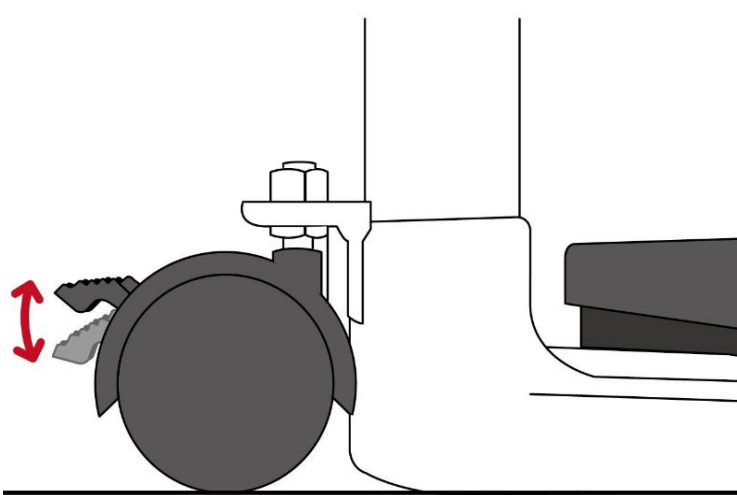



## B. Replacing Batteries

1. Open battery housing cover, and remove battery holder from compartment.

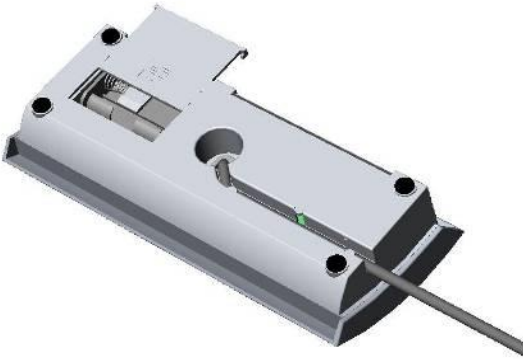

2. Disconnect rechargeable battery cable from connector in the battery compartment

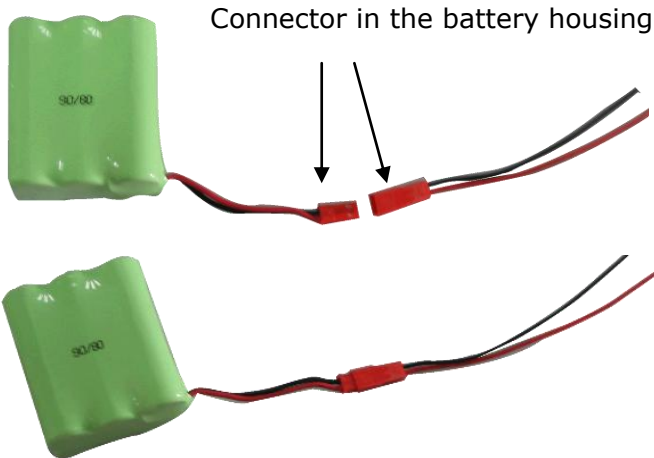

3. Connect cable with connector, and insert rechargeable battery pack in battery compartment.

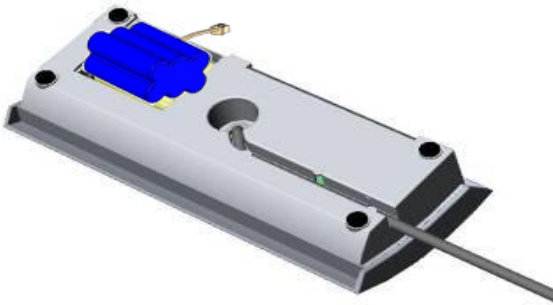

4. Place battery cover in place



The rechargeable battery should be recharged at least once every 3 months, regardless of if the device has been used. Battery can be charged by plugging device's exclusive adapter into AC Connector Port.

After a long period in storage (e.g. >3 months), the battery should run a full cycle (charge/discharge) to allow it to restore full capacity.

If Lo prompt displays on the LCD, please charge battery promptly to avoid battery damage.

## C. Using Adapter

1. Connect adapter to indicator before connecting to mains power supply
2. Disconnect adapter from mains power supply before unplugging adapter pin from indicator.

**NOTE:** Connect adapter to charge rechargeable batteries. Please charge batteries for at least 14 hours before first use.

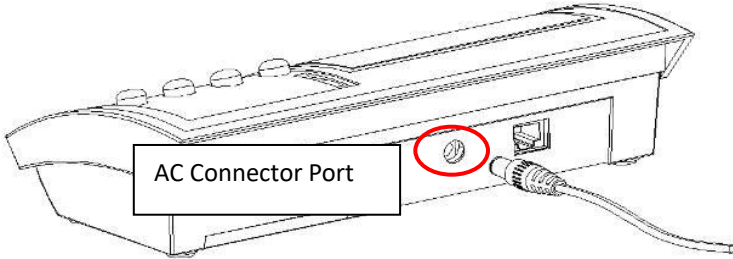

## D. Attaching Height Rod to Column



Step 1. Attach two fixing blocks to column using four flat-head screws



Step 2. Attach height rod to blocks using two flat-head screws

Item	Name	Quantity
1	Fixing block screws	4
2	Fixing blocks	2
3	Height Rod to fixing block screws	2

\* Photo of display for reference only. Please refer to the actual product.

## E. Using HM201M Height Rod

### Measurement over 121 cm

1. Pull out rod

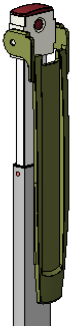

2. Unfold head piece to horizontal position

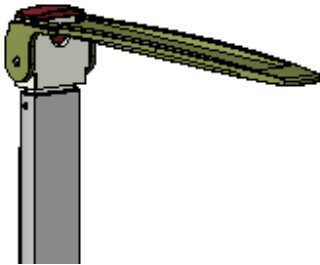

3. Height reading found at point A

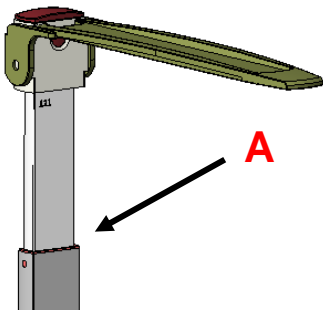

## Measurement under 121 cm

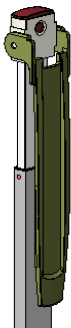

1. Fold head piece and press buckle

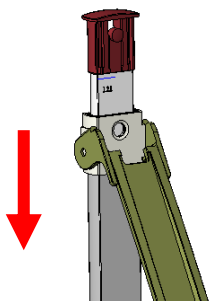

2. While pressing on buckle, pull down head piece

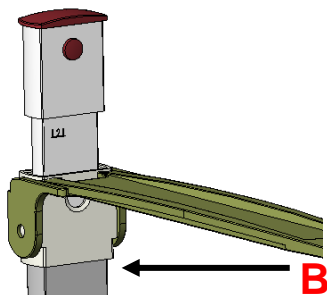

3. Height reading found at point B

## V. Indicator

### A. Indicator and Key Functions

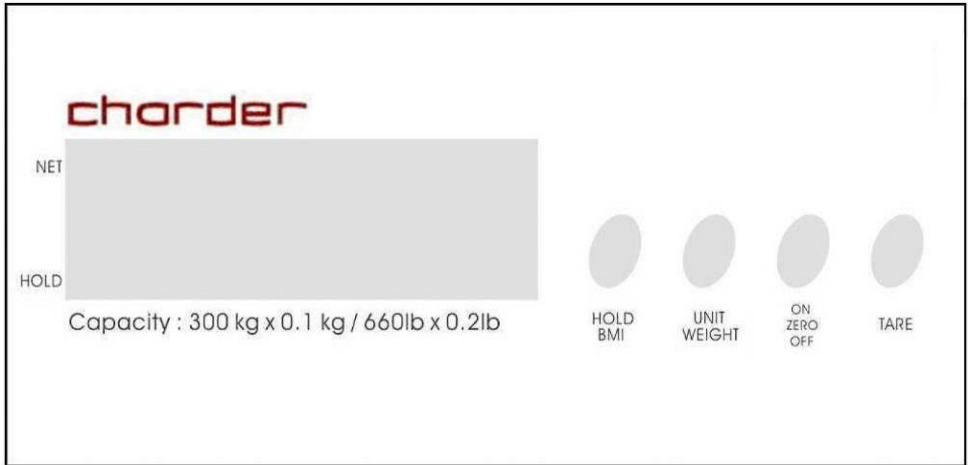

#### Key Function

1. **HOLD/BMI**: Determine stable weighing value - used when weight is unstable. Press and hold for 3 seconds to enter BMI mode.
2. **UNIT/WEIGHT**: Switch between kg/lb. Change height value when indicator is in BMI mode.
3. **ON/ZERO/OFF**: Power on or power off. Zero weight value.
4. **TARE**: Allows user to deduct weight from reading.

## VI. Using Device

### A. Basic Operation

Switch on the device using **[ON/ZERO/OFF]** key. The device will automatically perform self-calibration, displaying software version.

Once "0.0 kg" appears on indicator, device is ready for measurement.

**Note:** If "0.0 kg" does not display on indicator, press **[ON/ZERO/OFF]** key to zero the device. This function can be used for weight within  $\pm 2\%$  of full capacity.

Guide subject to stand upon the measurement platform. After the weight has stabilized, the "stable" symbol will appear on indicator.

**Note:** If subject's weight exceeds scale capacity (including tare), indicator will display "Err" prompt due to overload.

### B. Hold

The hold function determines average weight, designed to be used if subject's weight will not stabilize (ex: an active child).

**Note:** if fluctuation is too severe, average weight determination will be difficult and hold may not function correctly

1. Switch on the device normally.
2. Press the **[HOLD/BMI]** key. An arrow will blink next to the "HOLD" mark on the indicator.
3. Guide subject to stand on measurement platform.
4. After a few seconds, the average weight will be displayed on the indicator. This weight will be locked - at this point, subject can step off from device.
5. To release the locked weight, press the **[HOLD/BMI]** key again to return to the device to normal mode.

**Note:** Hold function can be activated before or after subject stands on measurement platform. However, if subject finds it difficult to stand still, we recommend activating Hold after subject stands on platform.



## C. BMI

1. In normal mode, press and hold the **[HOLD/BMI]** key for at least 3 seconds to enter BMI mode.
2. Display will show last recorded height. Left-most digit will flash.
3. Press **[UNIT/WEIGHT]** key to change height value. Press **[HOLD/BMI]** key to manually move to next digit.
4. After inputting height, press **[TARE]** to confirm.
5. Proceed to weigh subject as usual. Indicator will alternate between weight and BMI display.

**NOTE:** Hold function can be used at this time if weight is unstable

6. Press and hold **[HOLD/BMI]** key to return to normal mode.

Category	BMI (kg/m <sup>2</sup> )	Risk of obesity-related disease
Under	< 18.5	Low
Normal	18.5-24.9	Average
Over	24.9-29.9	Slightly Increased
Obese I	30.0-34.9	Increased
Obese II	35.0-39.9	High
Obese III	> 40	Very High

(World Health Organization adult BMI standards)

## D. Tare

The tare function allows the user to deduct the weight of objects from the device's measurement result.

1. Place object that needs to be tared onto measurement platform.
2. Press **[TARE]** key after stable symbol appears on indicator. Display will indicate "0.0 kg".
3. Guide subject (plus tared object) to be weighed upon measurement platform. Conduct measurement.
4. To clear tare value, remove all objects from measurement platform, and press **[TARE]** key.

## VII. Device Setup

### Calibration Procedure

- 1) Press and hold **[ON/ZERO/OFF]** button. Without letting go of the **[ON/ZERO/OFF]** button, press **[UNIT/WEIGHT]** button 3 times.
- 2) LCD screen will display a zero count value between 2000 and 10000.
- 3) Press **[UNIT/WEIGHT]** to select calibration weight unit (kg/lb)
- 4) Press **[TARE]** button. Screen will display "0".
- 5) Select weight according to calibration unit.  
(20 kg capacity used as example)  
(Do not place any objects on measurement platform at this time)

[UNIT] key: Digit+1 [HOLD] key: Digit displacement [TARE] key: Confirm
--

- 6) Load 20 kg on the measurement platform
- 7) Display will show span count value.
- 8) Press **[TARE]** button. Screen will display "CAL1", followed by "20 kg".
- 9) Press **[TARE]** button. Screen will display "0".
- 10) Select weight according to calibration unit.  
(30 kg capacity used as example)  
(Do not place any objects on measurement platform at this time)

[UNIT] key: Digit+1 [HOLD] key: Digit displacement [TARE] key: Confirm
--

- 11) Load 30 kg on the measurement platform
- 12) Display will show span count value.
- 13) Press **[TARE]** button. Screen will display "CAL2", followed by "30 kg".

## VIII. Troubleshooting

### Product Defects

Charder's warranty is effective for the original purchaser of this device, subject to the terms and conditions listed in the Warranty Program & Return Policy.

1. If Charder is responsible for a fault or defect present upon receipt of the unit, Charder shall either repair the fault, or supply a replacement unit. Should the repairs or replacement delivery fail, statutory provisions shall be valid. The period of warranty shall be two years, beginning on the date of purchase. Please retain your receipt as proof of purchase.
2. No responsibility shall be accepted for damage caused through any of the following reasons: unsuitable or improper storage or use, incorrect installation or commissioning by the owner or third parties, natural wear and tear, changes or modifications, incorrect or negligent handling, chemical, electrochemical, or electrical interference, unless damage is attributable to negligence on the part of Charder.

If device is not covered under warranty, a service maintenance charge will apply, plus cost of replacement parts.

Before contacting your local Charder distributor for repair service, we recommend considering the following troubleshooting procedures:

### Self-inspection

#### 1. Device will not power on

- If battery power is depleted, replace with new batteries (or charge batteries)
- If batteries are not used, check if the power adapter is plugged into the device properly. Check if power adapter is plugged into mains properly

#### 2. Indicator showing "0000" ZERO SPAN out of range

- Interference due to factors such as RF disturbance or ground vibration. Relocate device to location without interference and try again
- Unstable platform feet
- External objects interfering with measurement platform. Clear platform of objects and try again

- Device may not function properly on soft surfaces such as carpets or lawns. Relocate device to location with solid, stable floor
- If the steps above cannot resolve the problem, re-calibration may be required to correct weighing accuracy

### **3. Connection failure for data transmission**

- Ensure wires are connected correctly

### **Distributor support required**

If the following errors occur, we recommend contacting your local Charder distributor for repair or replacement services:



#### **1. Device will not power on**

- Faulty on/off key
- Broken or damaged wires causing short circuit or faulty connection
- Safety fuse burnout
- Faulty adapter

#### **2. Indicator damage**

- Possible hardware defects include: uneven brightness in LCD screen, blurred text, smeared rainbow screen, incorrect decimal display
- Unable to save or read data
- Indicator shows "ERRL" after device is switched on
- Keys not responding
- Buzzer malfunction

## Error Messages

Error Message	Reason	Action
	<b>Low battery warning</b> Voltage of battery is too low to operate device	Replace batteries, or plug in adapter
	<b>Overload</b> Total load exceeds device's maximum capacity	Reduce weight on measurement platform and try again
	<b>Counting Error (too low)</b> Signal from loadcells too low	Error normally caused by faulty loadcell or wiring. Please contact distributor

## IX. Product Specifications

### A. Device Information

<b>Model</b>		<b>MS3400-1</b>
<b>Display</b>		DP2701
<b>Weight Measurement</b>	<b>Capacity</b>	300 kg x 0.1kg
	<b>Accuracy</b>	±0.2 kg
	<b>Unit</b>	kg / lb
	<b>LCD Screen</b>	1.0-inch LCD screen
<b>Dimensions</b>	<b>Overall</b>	310(W) x 460(D) x 1070(H) mm
	<b>Platform</b>	310(W) x 310(D)
	<b>Column</b>	900 mm
	<b>Device Weight</b>	5.3 kg
<b>Key Functions</b>		On/Zero/Off, Hold/BMI, Unit/Weight, Tare
<b>Power Supply</b>		Rechargeable battery / adapter
<b>Operation Environment</b>		+5°C~+35°C 15% / 85% RH 700 hPa ~1060 hPa
<b>Optional Accessories</b>		Height Meter
<b>Standard Accessories</b>		User manual x 1; Power Adapter x 1, RS232 Cable

## B. Power Adapter Standards



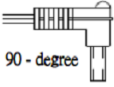

### Warning

The device is only compatible with the power adapters specified in the dashed block below.

AMP VOLTAGE	DRAWING NO.	CE APPROVED TYPE NO. / MODEL NO.	TYPE	Adapter plug
12V 1A	CD-AD-00044	UES12LCP-120100SPA	US	 90 - degree
	CD-AD-00044	UES12LCP-120100SPA	EU	
	CD-AD-00044	UES12LCP-120100SPA	UK	
	CD-AD-00044	UES12LCP-120100SPA	AU	

## C. Standard Parts

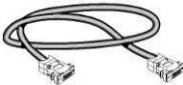
No.	Accessories	Item	Spec	Qty
1		M4 Screw	M4*0.7*15	3
2		M4 Screw	M4*0.7*8	4
3		Bottom Cover		1
4		RS232 cable	WR-2781	1





# Notes

---

---

---

---

---

---

---

---

---

---

---

---

---

---

---

---

---

---

---

---

---

---

---

---

---

# Notes

---

---

---

---

---

---

---

---

---

---

---

---

---

---

---

---

---

---

---

---

---

---

---

---

---

---

---



---

---

---

# X. Declaration of Conformity

This product has been manufactured in accordance with the harmonized European standards, following the provisions of the below stated directives:

	(EU) 2017/745 Regulation on Medical Devices
	2014/31/EU Non-automatic Weighing Instruments Directive (OIML models only)

## RoHS Directive 2011/65/EU and Delegated Directive (EU) 2015/863

### Radio Equipment Directive 2014/53/EU

(applicable if wireless module is used)

### Part 15 of the Federal Communications Statement Rules

This device may not cause harmful interference.

This device must accept any interference received, including interference that may cause undesired operation.

*Please see separate document showing on sticker of device for above markings.*

Authorized EU Representative:



**Obelis s.a.**

Bd Général Wahis, 53  
B-1030 Brussels  
Belgium

### Manufactured by:



Charder Electronic Co., Ltd.  
No.103, Guozhong Rd., Dali Dist.,  
Taichung City 41262 ,Taiwan

CD-IN-00116 REV008 08/2024