



## Chair Scale

# USER MANUAL **MS5480**

















Please keep the instruction manual at hand and follow instruction for use.



# CONTENTS

<b>I. Explanation of Graphic Symbols on Label/Packaging</b> .....	<b>4</b>
<b>II. Copyright Notice</b> .....	<b>6</b>
<b>III. Safety Notes</b> .....	<b>7</b>
A. General Information .....	7
B. EMC Guidance and Manufacturer's Declaration .....	11
<b>IV. Installation</b> .....	<b>15</b>
A. Unfolding device .....	15
B. Using adapter and charging battery.....	18
C. Replacing Rechargeable Battery Pack.....	18
D. Optional Accessories .....	19
<b>V. Indicator</b> .....	<b>20</b>
A. Indicator and Key Functions .....	20
B. Display layout.....	21
<b>VI. Basic Operation</b> .....	<b>22</b>
A. Basic Operation .....	22
B. Weight measurement .....	23
C. BMI calculation .....	23
D. Tare .....	24
E. Pre-Tare .....	24
<b>VII. Device Setup</b> .....	<b>28</b>
<b>VIII. Connecting scale to receiving device</b> .....	<b>29</b>
<b>IX. Troubleshooting</b> .....	<b>30</b>
<b>X. Product Specifications</b> .....	<b>32</b>
A. Device Information .....	32
B. Power Adapter Standards .....	33
<b>XI. Declaration of Conformity</b> .....	<b>36</b>

# I. Explanation of Graphic Symbols on Label/Packaging

Text/Symbol	Meaning
	Caution, consult accompanying documents before use
	Separate collection for waste of electrical and electronic equipment, in accordance with Directive 2002/96/EC. Do not dispose of device with everyday waste
	Name and address of device manufacturer, and year/country of manufacture
	Carefully read user manual before installation and usage, and follow instructions for use.
	Medical electrical device, Type B applied part
	Medical electrical device, Type BF applied part
	Device catalogue number / model number
	Name and address of authorized representative in the European Union
	Device is a medical device. Text indicates device category type
	Manufacturer's batch or lot number for device
	Device's serial number
	Device's Unique Device Identifier
	Verification Scale Interval. Value expressed in units of mass. Used to classification and verification of an instrument.
	Device conforms to (EU) 2017/745 Regulation on Medical Devices. Fourdigit number is identifier for medical device Notified Body

Device complies with EC directives (verified models only)

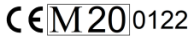

**M**: Conformity label in compliance with Directive 2014/31/EU for non-automatic weighing instruments  
**20**: Year in which conformity verification was performed and the CE label was applied. (ex: 16=2016)  
**0122**: Identifier for metrology Notified Body



Device is a Class III scale in compliance with Directive 2014/31/EU (verified models only)



Name and address of entity importing device (if applicable)



Name and address of entity responsible for translating Information For Use (if applicable)



Event counter confirming how many times device has been calibrated (if applicable)



Device conforms to Taiwan National Communications Commission(NCC) approval



Device conforms to U.S. Federal Communications Commission regulations

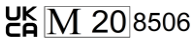

Device complies with UK non-automatic weighing instruments regulations 2016 (verified models only)  
**M**: Conformity label in compliance with Non-automatic Weighing instruments Regulations 2016  
**20**: Year in which conformity verification was performed and the UKCA label was applied. (ex: 20=2020)  
**8506**: Identifier for metrology approved body



Device complies with all UK applicable product legislation



Device's polarity of power.

**"In case of differences, icon on device itself takes precedence"**

## II. Copyright Notice

### **Copyright Notice**

#### **Charder Electronic Co., Ltd.**

No.103, Guozhong Rd., Dali Dist., Taichung City 41262 Taiwan

Tel: +886-4-2406 3766

Fax: +886-4-2406 5612

Website: [www.chardermedical.com](http://www.chardermedical.com)

E-mail: [info\\_cec@charder.com.tw](mailto:info_cec@charder.com.tw)

Copyright© Charder Electronic Co., Ltd. All rights reserved.

This user manual is protected by international copyright law.

All content is licensed, and usage is subject to written authorization from Charder Electronic Co., Ltd. (hereinafter Charder)

Charder is not liable for any damage caused by a failure to adhere to requirements stated in this manual.

Charder reserves the right to correct misprints in the manual without prior notice, and modify the exterior of the device for quality purposes without customer consent.



Charder Electronic Co., Ltd.  
No. 103, Guozhong Rd., Dali Dist.,  
Taichung City, 41262 Taiwan

## III. Safety Notes

### A. General Information

Thank you for choosing this Charder Medical device. It is designed to be easy and straightforward to operate, but if you encounter any problems not addressed in this manual, please contact your local Charder service partner.

Before beginning operation of the device, please read this user manual carefully, and keep it in a safe place for reference. It contains important instructions regarding installation, proper usage, and maintenance.

### Intended Purpose

This medical device is designed to be used in accordance with national regulations, to measure weight within specifications, for weight-related usage by professionals.

### Clinical Benefit

Measurement results can be used by professionals to diagnose (and monitor) weight-related issues.

### Intended medical indications/contraindications

Measurement: patient's body weight. No known contraindications to measurement of body weight.

### Intended patient profile

- (a) Age: no restrictions
- (b) Weight: no restrictions within device weight capacity
- (c) Patient Conditions: require measurement of body weight. Unable to stand independently without support.

### Intended user profile

- (a) At least 20 years old
- (b) Minimum knowledge:
  - To be able to read at a high-school level and understand Arabic numerals (e.g. 1, 2, 3, 4...)
  - Basic hygiene knowledge
  - Trained in device's operation
  - Read the instruction manual

- (c) Language
  - Able to read the language of instruction manual and on-screen instructions
- (d) Qualifications
  - No special certifications or qualifications required

### **Residual risk evaluation**

- (a) All foreseeable risks have been evaluated and considered acceptable. Generally speaking, the most likely risk caused by incorrect usage of the device is less accurate measurement (or inability to use device to acquire measurement), which does not pose imminent physical risk to patient or user.
- (b) Benefit-risk ratio is considered acceptable. Chair scales are an important option for measuring patients. Usage of device is unlikely to result in harm to user or patient.

### **General Handling**

- Ensure all parts are properly locked and tightened before operating the device.
- Measurement accuracy requires the subject's feet, back, and head to be straightly aligned. Please note that height can vary throughout the day
- **CAUTION:** Do not use next to equipment that may cause electromagnetic or other types of interference.

### **Safety Instructions**

Before putting device into use, please read this user manual carefully. It contains important instructions for installation, usage, and maintenance of device.

The manufacturer shall not be liable for damages caused by failure to heed the following instructions:

- The device has an expected service life of 5 years when correctly handled, serviced, and periodically inspected in accordance with manufacturer's instructions.
- Improper installation will render the warranty null and void.
- Observe permissible ambient temperatures for use



## Cleaning

- Device surface should be cleaned using alcohol-based wipes.

## Maintenance

- Please contact your local Charder distributor for regular maintenance and calibration, regular checking of accuracy is recommended; frequency to be determined by level of use and state of device.

## Warranty/Liability

- The period of warranty shall be eighteen(18) months, beginning on the date of purchase. Please retain your receipt as proof of purchase.
- No responsibility shall be accepted for damage caused through any of the following reasons: unsuitable or improper storage or use, incorrect installation or commissioning by the owner or third parties, natural wear and tear, changes or modifications, incorrect or negligent handling, chemical, electrochemical, or electrical interference, unless damage is attributable to negligence on the part of Charder.
- This device does not contain any user-maintained parts. All maintenance, technical inspections, and repairs should be conducted by an authorized Charder service partner, using original Charder accessories and spare parts. Charder is not liable for any damages arising from improper maintenance or usage. Dismantlement of the device will void the warranty.



## Warning

Measurements for physically disabled persons.

- Physically disabled persons should not attempt to take measurements alone, but instead should have their caretakers assist them in using the device.
- Footrest can only be used when subject is sitting in chair. To avoid injury, subject should refrain from standing on footrest, as device may tip over if used incorrectly.





### **Warning**

- The collapsible frame should be handled with caution. Keep fingers, hands, or other parts of the body clear when folding or unfolding frame, to avoid injury.



### **Incident Reporting**

- Any serious incident that has occurred in relation to the device should be reported to the manufacturer, EU representative (if device is used in EU member state), and competent authority of user/subject's member state.

## B. EMC Guidance and Manufacturer's Declaration

<b>Guidance and manufacturer's declaration-electromagnetic emissions</b>		
The product is intended for use in the electromagnetic environment specified below. The customer or the user of the product should assure that it is used in such an environment.		
<b>Emission test</b>	<b>Compliance</b>	<b>Electromagnetic environment-guidance</b>
RF emissions CISPR 11	Group 1	The product uses RF energy only for its internal function. Therefore, its RF emissions are very low and are not likely to cause any interference in nearby electronic equipment.
RF emissions CISPR 11	Class A	The product is suitable for use in all establishments other than domestic and those directly connected to a low voltage power supply network which supplies buildings used for domestic purposes.
Harmonic emissions IEC 61000-3-2	Class A	
Voltage fluctuations /flicker emissions IEC 61000-3-3	Compliance	

### Guidance and manufacturer's declaration-electromagnetic immunity

The product is intended for use in the electromagnetic environment specified below.

The customer or the user of the product should assure that it is used in such an environment.

Immunity test	IEC 60601 test level	Compliance level	Electromagnetic environment-guidance
Electrostatic discharge(ESD) IEC 61000-4-2	<u>±8 kV contact</u> <u>±2 kV, ±4 kV, ±8 kV, ±15 kV air</u>	<u>±8 kV contact</u> <u>±2 kV, ±4 kV, ±8 kV, ±15 kV air</u>	Floors should be wood, concrete or ceramic tile. If floors are covered with synthetic material, the relative humidity should be at least 30%
Electrical fast transient/burst IEC 61000-4-4	<u>± 2kV for power supply lines</u>	<u>± 2kV for power supply lines</u>	Mains power quality should be that of a typical commercial or hospital environment.
Surge IEC 61000-4-5	<u>± 1kV line(s) to line(s)</u> <u>± 2kV line(s) to earth</u>	<u>± 1kV line(s) to line(s)</u> <u>± 2kV line(s) to earth</u>	Mains power quality should be that of a typical commercial or hospital environment.
Voltage Dips, short interruptions and voltage variations on power supply input lines IEC 61000-4-11	<u>0% UT for 0.5 cycle</u> <u>0% UT for 1 cycle</u>  <u>70% UT(30% dip in UT) for 25cycles</u>  <u>0% UT for 5 s</u>	<u>0% UT for 0.5 cycle</u> <u>0% UT for 1 cycle</u>  <u>70% UT(30% dip in UT) for 25cycles</u>  <u>0% UT for 5 s</u>	Mains power quality should be that of a typical commercial or hospital environment. If the user of the product requires continued operation during power mains interruptions, it is recommended that the product be powered from an uninterruptible power supply or a battery.
Power frequency (50, 60 Hz) magnetic field IEC 61000-4-8	<u>30 A/m</u>	30 A/m	The product power frequency magnetic fields should be at levels characteristic of a typical location in a typical commercial or hospital environment.

NOTE UT is the a.c. mains voltage prior to application of the test level.

## Guidance and manufacturer's declaration-electromagnetic immunity

The product is intended for use in the electromagnetic environment specified below.  
The customer or the user of the product should assure that is used in such and environment.

Immunity test	IEC 60601 test level	Compliance level	Electromagnetic environment-guidance
Conducted RF IEC 61000-4-6	3 Vrms 150 KHz to 80 MHz  <u>6 V in ISM bands between 0,15 MHz and 80 MHz</u> <u>80 % AM at 1 kHz</u>	3 Vrms 150 KHz to 80 MHz  <u>6 V in ISM bands between 0,15 MHz and 80 MHz</u> <u>80 % AM at 1 kHz</u>	<p>Portable and mobile RF communications equipment should be used no closer to any part of the product including cables, than the recommended separation distance calculated from the equation applicable to the frequency of the transmitter.</p> <p><b>Recommended separation distance:</b>  <math>d = 1,2 \sqrt{P}</math>  <math>d = 1,2 \sqrt{P}</math> 80MHz to 800 MHz <math>d = 2,3 \sqrt{P}</math> 800MHz to 2,7GHz                      Where <math>P</math> is the maximum output power rating of the transmitter in watts (W) according to the transmitter manufacturer and <math>d</math> is the recommended separation distance in metres(m).</p> <p>Field strengths from fixed RF transmitters, as determined by an electromagnetic site survey, <sup>a</sup> should be less than the compliance level in each frequency range<sup>b</sup></p> <p>Interference may occur in the vicinity of equipment marked with the following symbol:</p> <div style="text-align: center;">  </div>
Radiated RF IEC 61000-4-3	3 V/m <u>80MHz to 2,7 GHz</u>	3 V/m <u>80MHz to 2,7 GHz</u>	

NOTE1 At 80 MHz and 800 MHz, the higher frequency range applies.

NOTE2 These guidelines may not apply in all situations. Electromagnetic propagation is affected by absorption and reflection from structures, objects and people.

a Field strengths from fixed transmitters, such as base stations for radio (cellular/cordless) telephones and land mobile radios, amateur radio, AM and FM radio broadcast and TV broadcast cannot be predicted theoretically with accuracy. To assess the electromagnetic environment due to fixed RF transmitters, an electromagnetic site survey should be considered. If the measured field strength in the location in which the product is used exceeds the applicable RF compliance level above, the product should be observed to verify normal operation. If abnormal performance is observed, additional measures may be necessary, such as re-orienting or relocating the product.

b Over the frequency range 150 kHz to 80 MHz, field strengths should be less than 3V/m.

**Recommended separation distance between portable and mobile RF communications equipment and the product**

The product is intended for use in an electromagnetic environment in which radiated RF disturbances are controlled. The customer or the user of the product can help prevent electromagnetic interference by maintaining a minimum distance between portable and mobile RF communications equipment (transmitters) and the product as recommended below, according to the maximum output power of the communications equipment.

Rated maximum output power of transmitter W	Separation distance according to frequency of transmitter m		
	150 kHz to 80 MHz $d = 1,2\sqrt{P}$	80 MHz to 800 MHz $d = 1,2\sqrt{P}$	800 MHz to 2,7 GHz $d = 2,3\sqrt{P}$
0,01	0,12	0,12	0,23
0,1	0,38	0,38	0,73
1	1,2	1,2	2,3
10	3,8	3,8	7,3
100	12	12	23

For transmitters rated at a maximum output power not listed above, the recommended separation distance  $d$  in metres(m) can be estimated using the equation applicable to the frequency of the transmitter, where  $p$  is the maximum output power rating of the transmitter in watts (W) according to the transmitter manufacturer.

NOTE1 At 80 MHz and 800 MHz, the separation distance for the higher frequency range applies.

NOTE2 These guidelines may not apply in all situations. Electromagnetic propagation is affected by absorption and reflection from structures, objects and people.

## IV. Installation

### A. Unfolding device

Device should arrive in folded form.

Rotate footrests into position.

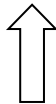
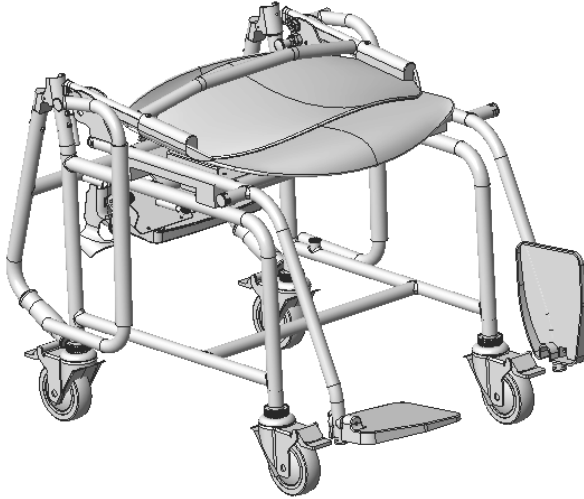

Raise seat back until joint locks

Pull frame lock to raise seat back

Lift handles until they automatically lock in place

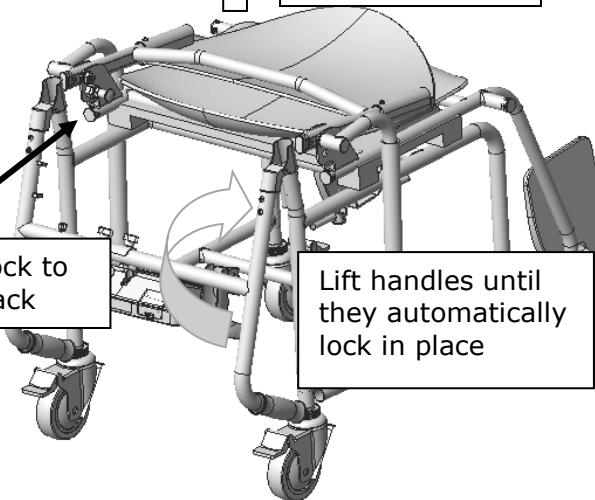

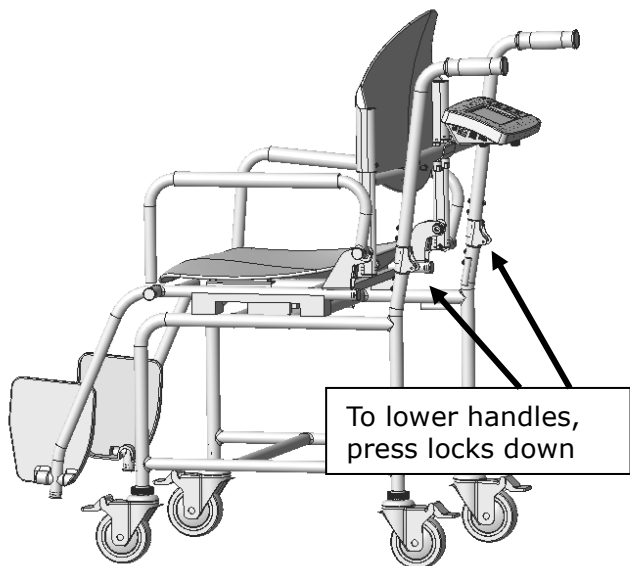

To lower handles,  
press locks down

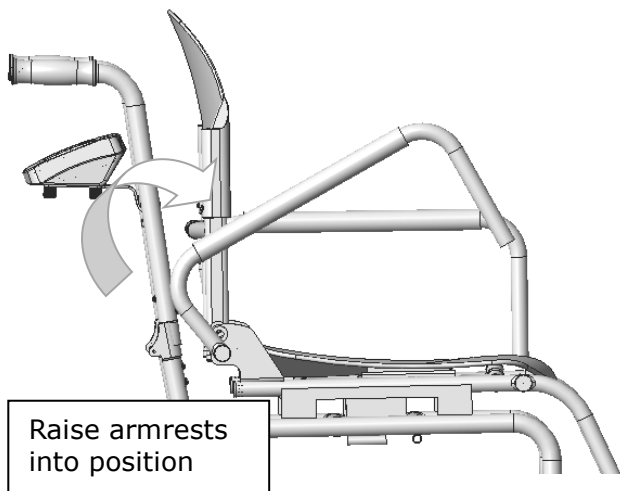

Raise armrests  
into position





## Engaging wheel brakes

Wheel brakes must be engaged prior to measurement. Press down on brakes to engage.





## B. Using adapter and charging battery

The rechargeable battery should be recharged at least once every 3 months, regardless of if the device has been used. Battery can be charged by plugging device's exclusive adapter into AC Connector Port.

After a long period in storage (e.g. >3 months), the battery should run a full cycle (charge/discharge) to allow it to restore full capacity.

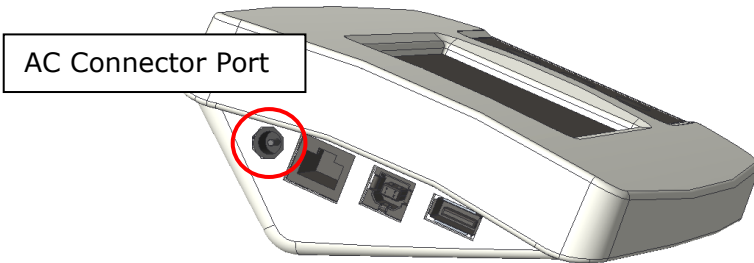
Ensure rechargeable battery housing is installed and inserted properly into the compartment.



If  prompt displays on the LCD, please charge battery promptly to avoid battery damage.

## C. Replacing Rechargeable Battery Pack

1. Open battery housing cover

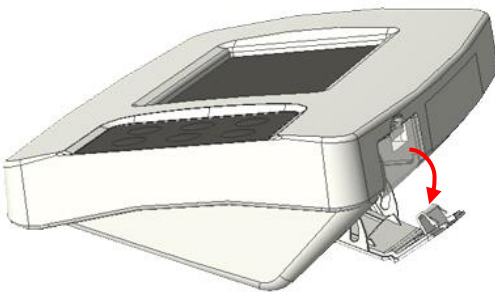

## 2. Accessing batteries

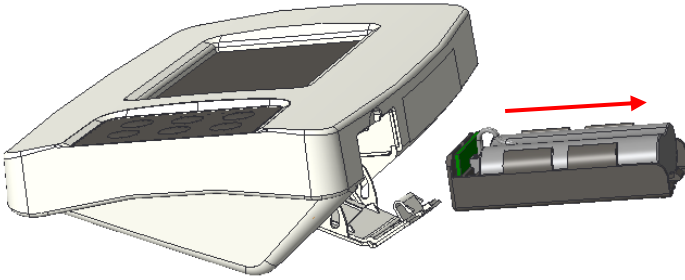

## 3. Place new battery pack into housing, and insert into indicator

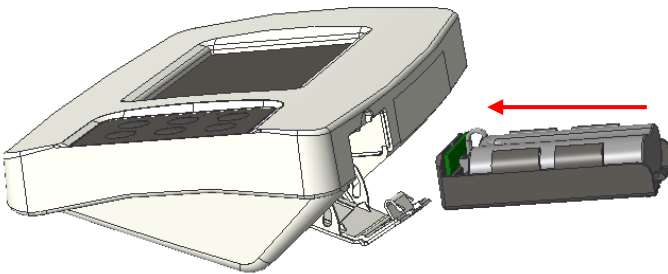

## 4. Close battery housing compartment cover. Turn on power to confirm that battery is correctly installed.

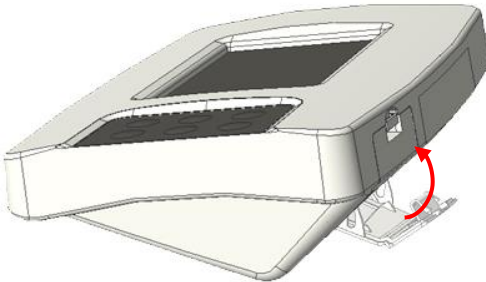

## D. Optional Accessories

This device is compatible with a variety of accessories. Please consult their respective user manuals for assembly instructions:

### a. Barcode Scanner

- AS-9300 Infrared Barcode Scanner

## V. Indicator

### A. Indicator and Key Functions

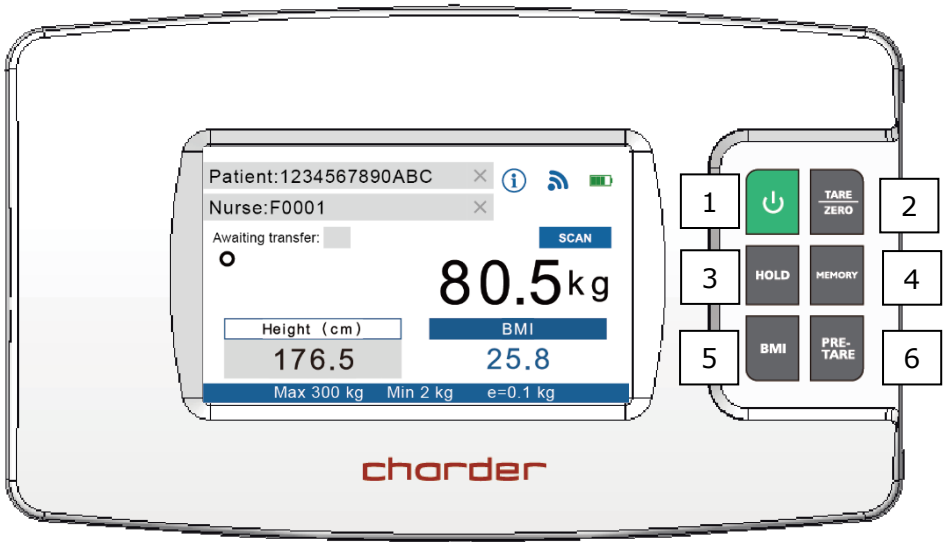

#### Key Function

 <b>POWER</b>	Power on or power off.
<b>TARE/ZERO</b>	Reset display to 0.0 kg display. Press and hold for 6 seconds to enter device settings.
<b>HOLD</b>	Determine stable weighing value - used when weight is unstable.
<b>MEMORY</b>	Save pre-tare values (up to 10 sets can be stored in device memory).
<b>BMI</b>	Calculation of Body Mass Index.
<b>PRE-TARE</b>	Pre-tare the known weight of an object (ex: chair) before beginning measurement.

## B. Display layout

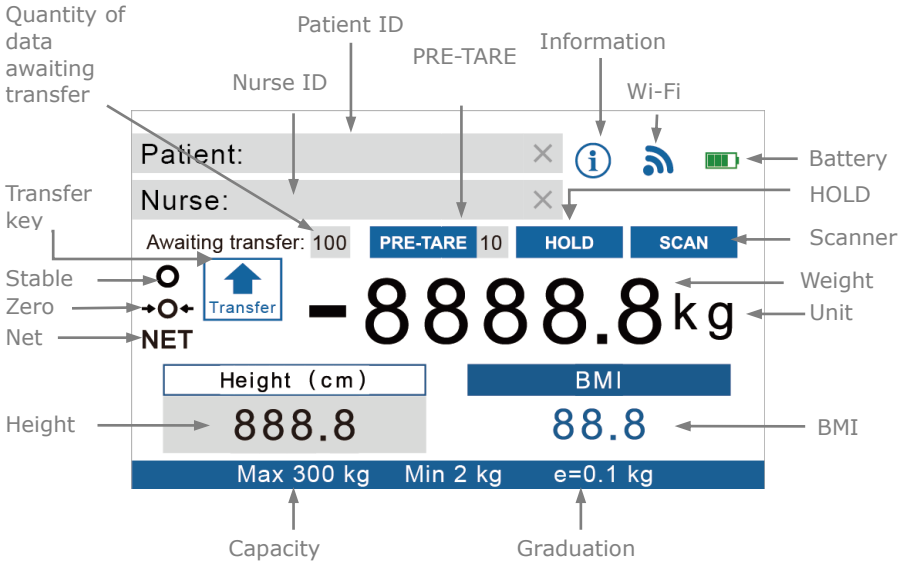

## Definitions

**Quantity of data awaiting transfer:** If device is not connected wirelessly, measurement results will be temporarily stored in device. Once device is connected, operator can press **Transfer** to send results wirelessly. After transfer is complete, number will revert to "0"

**PRE-TARE:** If Pre-Tare function is active, this indicates which pre-tare value is being used.

**HOLD:** Will appear if Hold is active. (Hold needs to be activated in order to save and transfer results)

**SCAN:** Will appear if compatible barcode scanner is plugged into device

**Transfer:** After measurement is completed, height/weight result can be transferred wirelessly (if Hold is active). Press **[Transfer]** to send results.

**Wi-Fi:** Indicator will reflect current Wi-Fi connectivity status.



disconnected



connected

## VI. Basic Operation

1. Switch on the device using  key. The device will automatically perform self-calibration
2. Once "0.0" appears on indicator, device is ready for use

**NOTE:** If "0.0" does not display on indicator, press [**TARE/ZERO**] key to zero the device.

### A. Basic Operation

#### Direct Wi-Fi data transfer

**NOTE:** If results do not need to be transferred after measurement, this step can be skipped.

1. The device acts as an Access Point that can be connected to via Wi-Fi. To ensure that the phone/tablet/PC connects to the correct device, first

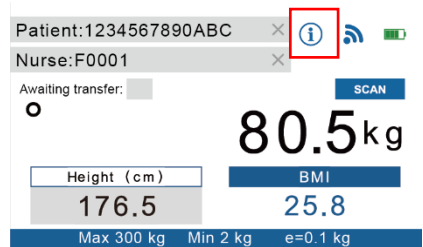

identify the device's MAC Address by clicking 

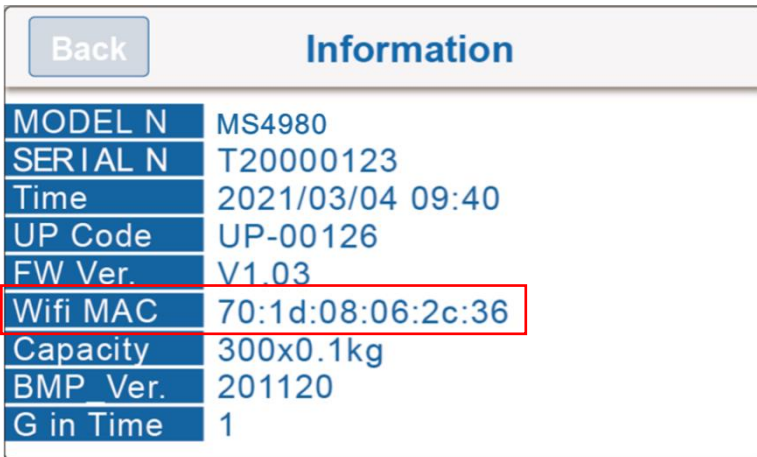



2. The "name" of the device's Wi-Fi Access Point will be "DP4800\_(MAC Address)" The default password to connect to the device is "00000000"

**NOTE:** The Model No. displayed in Information will vary depending on the

device model.

3. After the phone/tablet/PC is connected to the device, the wireless

symbol will change from  to 

4. Device is now ready to send results wirelessly to phone/tablet/PC.

5. Before or after measurement, press the **[HOLD]** key. "HOLD" will be displayed on the indicator. HOLD must be active, to transfer results.

**NOTE:** by default, patient ID, weight, and height must be filled in to transfer results. Otherwise, **[Transfer]** button will not appear. To allow transfer of "incomplete" results, please change settings (press and hold **[TARE/ZERO]** key for 6 seconds to enter settings).

## B. Weight measurement

1. Engage wheel brakes, raise footrests, and raise armrests.

2. Turn on device

3. Guide subject to sit on chair. Place subject's feet upon footrests. After a few seconds, the average weight will be displayed on the indicator. This weight will be locked - at this point, subject can stand up from chair.

4. If BMI calculation is unnecessary, press **[Transfer]** button to send results wirelessly. If device is not currently connected, results will temporarily be stored in device memory (number of records saved indicated by 'Awaiting transfer'). After transfer is complete, number will revert to "0"

## C. BMI calculation

1. Press the **[BMI]** key to enter BMI mode.

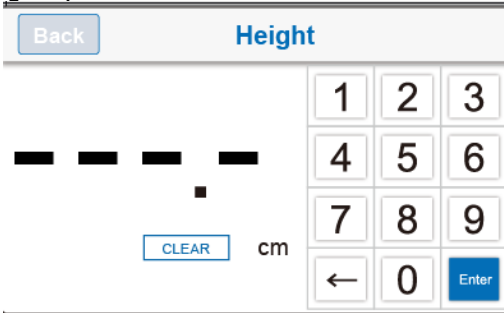

Back	Height		
	1	2	3
	4	5	6
	7	8	9
	←	0	Enter

2. Enter height using numeral keys (ex: to input 170 cm, press 1-7-0-0). Press **[CLEAR]** key to re-input.
3. After inputting height, press **[Enter]** to confirm.
4. Proceed to weigh subject as usual. Indicator will display weight, height, and BMI.
5. To transfer results, ensure that HOLD is active, and press **[Transfer]** button to send results wirelessly. If device is not currently connected, results will temporarily be stored in device memory (number of records saved indicated by 'Awaiting transfer'). After transfer is complete, number will revert to "0"

<b>Category</b>	<b>BMI (kg/m<sup>2</sup>)</b>	<b>Risk of obesity-related disease</b>
Under	< 18.5	Low
Normal	18.5-24.9	Average
Over	24.9-29.9	Slightly Increased
Obese I	30.0-34.9	Increased
Obese II	35.0-39.9	High
Obese III	> 40	Very High

(World Health Organization adult BMI standards)

## D. Tare

The tare function allows the user to deduct the weight of objects from the device's measurement result.

1. Place object that needs to be tared onto chair.
2. Press **[TARE/ZERO]** key after stable symbol appears on indicator. Display will indicate "0.0".
3. Guide subject (plus tared object) to be weighed upon chair. Conduct measurement.
4. To clear tare value, remove all objects from chair, and press **[TARE/ZERO]** key.

## E. Pre-Tare

The Pre-Tare function is used to subtract the known weight of a substance prior to weighing. The device can store 10 sets of pre-tare values in memory. Once pre-tare weights have been stored, they can be recalled by pressing the **[MEMORY]** key.

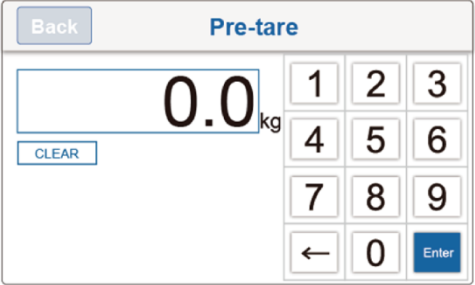
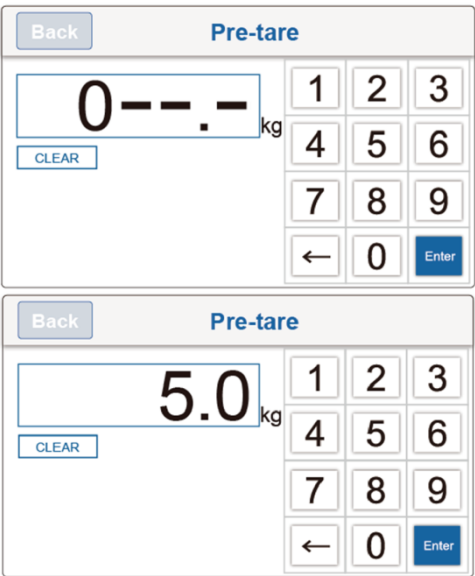
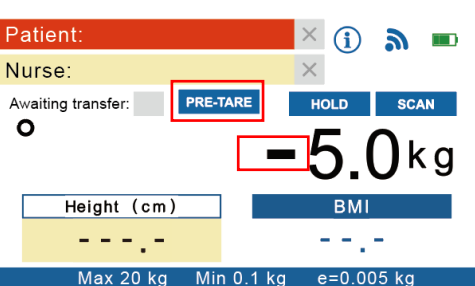

## Input Pre-Tare Value

DESCRIPTION	EXAMPLE
<p>Press <b>[PRE-TARE]</b> key. Input pre-tare weight value, starting from the left</p>	
<p>Enter pre-tare weight using 0~9 keys.</p> <p>Ex: to pre-tare 5.0 kg of weight, press 0-0-5-0.</p> <p>Ex: to pre-tare 13.5 kg of weight, press 0-1-3-5.</p> <p>Press <b>[Enter]</b> key to confirm the pre-tare weight.</p>	
<p>Device will return to measurement mode.</p> <p>Indicator will display minus sign to the left of pre-tare weight value.</p>	

## Save a Pre-Tare value

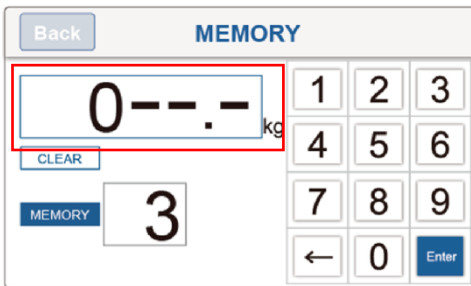
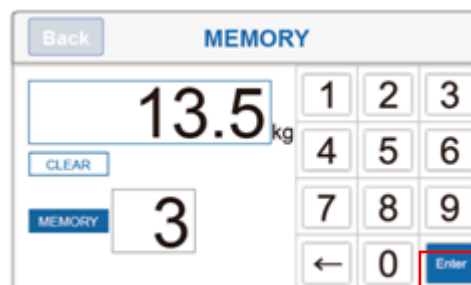
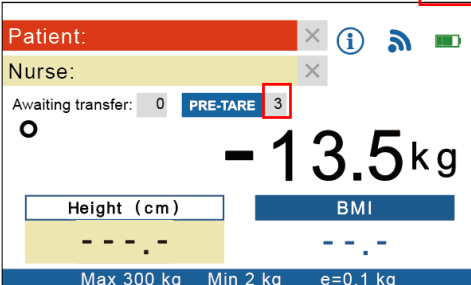
DESCRIPTION	EXAMPLE
<p>Press and hold <b>[MEMORY]</b> key for 3 seconds. Input the number for this pre-tare setting (between 01-10).</p> <p>Ex: To save memory set 3, press 0-3.</p>	 <p>The screenshot shows the 'MEMORY' screen with a 'Back' button at the top left. The main display shows '0.0 kg'. Below the display is a 'CLEAR' button and a 'MEMORY' button. To the right is a numeric keypad with buttons for digits 1-9, 0, and an 'Enter' button. The number '3' is shown in a red box on the keypad, indicating it is being entered.</p>
<p>Press the weight value box on the screen (marked in the red box to the right)</p> <p>Enter pre-tare weight using 0~9 keys.</p> <p>Ex: to pre-tare 13.5 kg of weight, press 0-1-3-5.</p>	 <p>The screenshot shows the 'MEMORY' screen with a 'Back' button at the top left. The main display shows '0--.- kg'. Below the display is a 'CLEAR' button and a 'MEMORY' button. To the right is a numeric keypad with buttons for digits 1-9, 0, and an 'Enter' button. The number '3' is shown in a box below the keypad, indicating it is being entered.</p>
<p>Press <b>[Enter]</b> key to store pre-tare weight (saved to memory set 3, in this example)</p>	 <p>The screenshot shows the 'MEMORY' screen with a 'Back' button at the top left. The main display shows '13.5 kg'. Below the display is a 'CLEAR' button and a 'MEMORY' button. To the right is a numeric keypad with buttons for digits 1-9, 0, and an 'Enter' button. The number '3' is shown in a box below the keypad, indicating it is being entered. The 'Enter' button on the keypad is highlighted with a red box.</p>
<p>PRE-TARE ID will show Pre-Tare memory set 3 as active, and deduct the pre-tare value (13.5 kg, in this example) from the displayed weight result.</p>	 <p>The screenshot shows the main weighing screen. At the top, there are status bars for 'Patient:' and 'Nurse:'. Below these, it says 'Awaiting transfer: 0'. The main display shows '-13.5 kg'. Below the display are fields for 'Height (cm)' and 'BMI'. At the bottom, it shows 'Max 300 kg', 'Min 2 kg', and 'e=0.1 kg'. The number '3' is shown in a red box next to 'PRE-TARE', indicating it is active.</p>

## Recall Pre-Tare Value

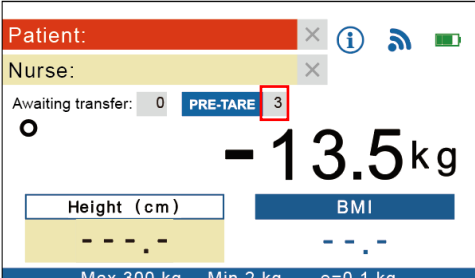
DESCRIPTION	EXAMPLE
<p>Press <b>[MEMORY]</b> key to toggle between Pre-Tare settings saved in device (between 01-10).</p> <p><b>NOTE:</b> to add new Pre-Tare value, please press and hold <b>[MEMORY]</b> key for 3 seconds to enter settings (see "Save a Pre-Tare value" above)</p>	 <p>The screenshot shows a scale interface with the following elements:</p> <ul style="list-style-type: none"><li>Top status bar: Patient (red), Nurse (yellow), and icons for info, Wi-Fi, and battery.</li><li>Input fields: "Patient:" and "Nurse:" with "X" icons.</li><li>Transfer status: "Awaiting transfer: 0" and a "PRE-TARE" button with a red box around the number "3".</li><li>Weight display: A large "- 13.5 kg" with a small circle icon to the left.</li><li>Input fields: "Height (cm)" and "BMI" with dashed lines below them.</li><li>Bottom bar: "Max 300 kg", "Min 2 kg", and "e=0.1 kg".</li></ul>

## VII. Device Setup

Press and hold **[TARE/ZERO]** key for 6 seconds to enter General Setting mode.

EXIT		General	
Auto Off Time	180s	G-Compensation	-----
Backlight	High	H.M. Calibration	-----
Buzzer	On	Height Capacity	High
Data Transfer	On	URL Host	-----
Date/Time	-----	Auto Hold	On
Wifi Setting	-----	Auto Transfer	On

Press menu options on the touchscreen to adjust settings.

**Auto Off Time:** Instruct device to shut off automatically after a certain period of time.

Auto off options: 120 sec / 180 sec / 240 sec / 300 sec / off

**Backlight:** adjust backlight brightness.

Options: Low / Mid / High

**Buzzer:** When function is turned on, beeping noise will be made when: indicator is turned on, keys are pressed, and weight is stable.

Options: Enable / Disable

**Data Transfer:** If enabled, all data fields (patient ID, weight, height) need to be completed to transfer data. If fields are incomplete (ex: only weight, no height or ID), data will not be transferred.

Options: Enable / Disable

**Date/Time:** Set device time. (Format: YYYY/MM/DD HH:M)

**WiFi Settings:** Send results via direct transfer or via network (set Access Point if selected)

**G-Compensation:** Authorized distributor can adjust gravity compensation value (password required)

**H.M. Calibration:** Calibrate ultrasonic height stadiometer

**Height Capacity:** Default setting is "High". This setting should be adjusted by distributor only - changing it may affect measurement accuracy.

**URL Host:** Set IP address (ex: 192.168.0.1). Please note that if server is restarted, another IP may be automatically assigned. If IP change occurs, please re-input correct IP once more to complete settings.

**Auto Hold:** Determine if hold function will be automatically activated on start-up

**Auto Transfer:** Determine if results will be automatically transferred after measurement completion

## VIII. Connecting scale to receiving device

The scale is designed to transfer results wireless to receiving device. Please consult instruction manual for receiving device.

Connection directly to Electronic Medical System should be conducted by qualified distributors/administrators only.

## IX. Troubleshooting

Before contacting your local Charder distributor for repair service, we recommend considering the following troubleshooting procedures:

### Self-inspection

#### 1. Device will not power on

- If battery power is depleted, replace with new batteries
- If batteries are not used, check if the power adapter is plugged into the device properly. Check if power adapter is plugged into mains properly







#### 2. Indicator showing "00000" ZERO SPAN out of range

- Interference due to factors such as RF disturbance or ground vibration. Relocate device to location without interference and try again
- Unstable platform feet - adjust platform feet according to bubble level indication (clockwise to retract, counter-clockwise to extend) and try again
- External objects interfering with measurement platform. Clear platform of objects and try again
- Device may not function properly on soft surfaces such as carpets or lawns. Relocate device to location with solid, stable floor
- If the steps above cannot resolve the problem, re-calibration may be required to correct weighing accuracy

#### 3. Connection failure for data transmission to PC or printer

- Ensure wires are connected correctly between indicator and PC or printer
- Ensure printer is supplied with power. Ensure PC software is set up properly as indicated in this manual

## Error Messages

Error Message	Action
<p> Low battery</p> <p>Please replace new batteries or plug the AC adaptor for operation.</p>	<p>Please charge battery using adapter, or replace battery</p>
<p> Overload</p> <p>Please reduce the loading and try again.</p>	<p>Maximum weight exceeded. Reduce weight on platform before attempting measurement</p>
<p> Loadcell error</p> <p>Please contact your nearest Authorized Dealer for further technician service &amp; repair.</p>	<p>If problem persists, please contact distributor</p>
<p> Zero count over calibration zero range</p> <p>Please re-calibrate this instrument.</p>	<p>Re-calibration may be required. If problem persists, please contact distributor</p>
<p> Zero count under calibration zero range</p> <p>Please re-calibrate this instrument.</p>	<p>Re-calibration may be required. If problem persists, please contact distributor</p>
<p> ADC error</p> <p>Please contact your nearest Authorized Dealer for further technician service &amp; repair.</p>	<p>If problem persists, please contact distributor</p>

## X. Product Specifications

### A. Device Information

<b>Model</b>		<b>MS5480</b>
<b>Display</b>		DP4800
<b>Weight Measurement</b>	<b>Capacity</b>	250kgx 0.1kg 550 lb x 0.2 lb
	<b>Accuracy</b>	±1.5e
	<b>Unit</b>	kg / lb
	<b>LCD Screen</b>	Color LCD touchscreen
<b>Dimensions</b>	<b>Overall</b>	590(W) x 1020(D) x 960(H) mm
	<b>Seat</b>	Height: 470mm Width: 460 mm Back Height: 480 mm
	<b>Armrest</b>	Height: 660 mm
<b>Device Weight</b>		17.6 kg
<b>Key Functions</b>		Power, Tare/Zero, Hold, Memory, BMI, Pre-Tare
<b>Data Transmission</b>		USB, Wireless <b>NOTE:</b> Device should be connected to network by qualified distributors only
<b>Power Supply</b>		Rechargeable battery pack / adapter
<b>Operation Environment</b>		+5°C~+35°C 15%~85% RH 700 hPa ~1060 hPa
<b>Standard Accessories</b>		User manual*1, Power Adapter*1
<b>Optional Accessories</b>		Barcode Scanner



## B. Power Adapter Standards



### Warning

Only the original adapter should be used with the device. Using an adapter other than the one provided by Charder may cause malfunction.

Amp Voltage: 5V/2A

Drawing No: CD-AD-00023



AMP VOLTAGE	DRAWING NO.:	CE APPROVED TYPE NO. / MODEL NO.:	TYPE	Adapter plug
5V 2A	AD-00023	UES12LCP-050200SPC	US	
5V 2A	AD-00023	UES12LCP-050200SPC	EU	
5V 2A	AD-00023	UES12LCP-050200SPC	UK	
5V 2A	AD-00023	UES12LCP-050200SPC	AU	





## XI. Declaration of Conformity

This product has been manufactured in accordance with the harmonized European standards, following the provisions of the below stated directives:

	<b>(EU) 2017/745 Regulation on Medical Devices</b>
	<b>2014/31/EU Non-automatic Weighing Instruments Directive</b> (OIML models only)

### **RoHS Directive 2011/65/EU and Delegated Directive (EU) 2015/863**

### **Radio Equipment Directive 2014/53/EU**

(applicable if wireless module is used)

### **Part 15 of the Federal Communications Statement Rules**

This device may not cause harmful interference.

This device must accept any interference received, including interference that may cause undesired operation.

*Please see separate document showing on sticker of device for above markings.*

Authorized EU Representative:



### **Manufactured by:**

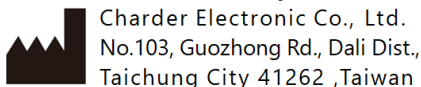

CD-IN-00391 REV003 08/2024