



Bed Scale

USER MANUAL **MS6000**

















Please keep the instruction manual at hand and follow instruction for use.

CONTENTS

| | |
|---|-----------|
| I. Explanation of Graphic Symbols on Label/Packaging | 4 |
| II. Copyright Notice | 6 |
| III. Safety Notes | 7 |
| A. General Information | 7 |
| B. EMC Guidance and Manufacturer's Declaration | 11 |
| IV. Installation | 15 |
| A. Setting up weight bridges | 15 |
| B. Inserting Batteries | 17 |
| V. Indicator | 20 |
| A. Indicator and Key Functions | 20 |
| B. Display layout | 21 |
| VI. Using Device | 22 |
| A. Performing measurement | 22 |
| B. Hold | 23 |
| C. BMI | 24 |
| VII. Advanced Operation | 25 |
| A. Pre-Tare | 25 |
| B. Weight Tracking & Alarm | 28 |
| VIII. Device Setup | 30 |
| A. Setting Time & Date | 30 |
| B. Device Setup | 31 |
| IX. Setup USB Connection to PC | 33 |
| X. Wireless Connection | 37 |
| XI. Troubleshooting | 38 |
| Product Defects | 38 |
| Self-inspection | 38 |
| Distributor support required | 39 |
| Error Messages | 40 |
| XII. Product Specifications | 41 |
| A. Device Information | 41 |
| B. Power Adapter Standards | 42 |
| XIII. Declaration of Conformity | 44 |

I. Explanation of Graphic Symbols on Label/Packaging

| Text/Symbol | Meaning |
|---|---|
|  | Caution, consult accompanying documents before use |
|  | Separate collection for waste of electrical and electronic equipment, in accordance with Directive 2002/96/EC. Do not dispose of device with everyday waste |
|  | Name and address of device manufacturer, and year/country of manufacture |
|  | Carefully read user manual before installation and usage, and follow instructions for use. |
|  | Medical electrical device, Type B applied part |
|  | Medical electrical device, Type BF applied part |
|  | Device catalogue number / model number |
|  | Name and address of authorized representative in the European Union |
|  | Device is a medical device. Text indicates device category type |
|  | Manufacturer's batch or lot number for device |
|  | Device's serial number |
|  | Device's Unique Device Identifier |
|  | Verification Scale Interval. Value expressed in units of mass. Used to classification and verification of an instrument. |
|  | Device conforms to (EU) 2017/745 Regulation on Medical Devices. Four-digit number is identifier for medical device Notified Body |

Device complies with EC directives (verified models only)

CE **M20** 0122 **M**: Conformity label in compliance with Directive 2014/31/EU for non-automatic weighing instruments
20: Year in which conformity verification was performed and the CE label was applied. (ex: 16=2016)
0122: Identifier for metrology Notified Body



Device is a Class III scale in compliance with Directive 2014/31/EU (verified models only)



Name and address of entity importing device (if applicable)



Name and address of entity responsible for translating Information For Use (if applicable)

CON.

Event counter confirming how many times device has been calibrated (if applicable)



Device conforms to Taiwan National Communications Commission(NCC) approval



Device conforms to U.S. Federal Communications Commission regulations

UK **M 20** 8506 Device complies with UK non-automatic weighing instruments regulations 2016 (verified models only)
M: Conformity label in compliance with Non-automatic Weighing instruments Regulations 2016
20: Year in which conformity verification was performed and the UKCA label was applied. (ex: 20=2020)
8506: Identifier for metrology approved body



Device complies with all UK applicable product legislation



Device's polarity of power.

"In case of differences, icon on device itself takes precedence"

II. Copyright Notice

Copyright Notice

Charder Electronic Co., Ltd.

No.103, Guozhong Rd., Dali Dist., Taichung City 41262 Taiwan

Tel: +886-4-2406 3766

Fax: +886-4-2406 5612

Website: www.chardermedical.com

E-mail: info_cec@charder.com.tw

Copyright© Charder Electronic Co., Ltd. All rights reserved.

This user manual is protected by international copyright law. All content is licensed, and usage is subject to written authorization from Charder Electronic Co., Ltd. (hereinafter Charder) Charder is not liable for any damage caused by a failure to adhere to requirements stated in this manual. Charder reserves the right to correct misprints in the manual without prior notice, and modify the exterior of the device for quality purposes without customer consent.



Charder Electronic Co., Ltd.
No. 103, Guozhong Rd., Dali Dist.,
Taichung City, 41262 Taiwan

III. Safety Notes

A. General Information

Thank you for choosing this Charder Medical device. It is designed to be easy and straightforward to operate, but if you encounter any problems not addressed in this manual, please contact your local Charder service partner.

Before beginning operation of the device, please read this user manual carefully, and keep it in a safe place for reference. It contains important instructions regarding installation, proper usage, and maintenance.

Intended Purpose

This medical device is designed to be used in accordance with national regulations, to measure weight within specifications, for weight-related usage by professionals.

Bed containing patient is pushed onto two weight bridges containing digital scale. Device measures weight of bed plus patient using digital scale. Both weight bridges are used simultaneously. By deducting weight of bed from total, weight of patient can be measured.

Clinical Benefit

Measurement results can be used by professionals to diagnose (and monitor) weight-related issues.

Intended medical indications/contraindications

Measurement: subject's body weight. No known contraindications to measurement of body weight.

Intended patient profile

- (a) Age: no restrictions
- (b) Weight: no restrictions within device weight capacity (Patient's weight limit is dependent upon bed weight. If bed weighs 50 kg, patients up to 450 kg can be weighed, if device capacity is 500 kg.)
- (c) Patient Conditions: require measurement of body weight.

Intended user profile

- (a) At least 20 years old
- (b) Minimum knowledge:
 - To be able to read at a high-school level and understand Arabic numerals (e.g. 1, 2, 3, 4...)
 - Basic hygiene knowledge
 - Trained in device's operation
 - Read the instruction manual
- (c) Language
 - Able to read the language of instruction manual and on-screen instructions
- (d) Qualifications
 - No special certifications or qualifications required
 - Able to push bed onto measurement platform. Two users recommended.

Residual risk evaluation

- (a) All foreseeable risks have been evaluated and considered acceptable. Generally speaking, the most likely risk caused by incorrect usage of the device is less accurate measurement (or inability to use device to acquire measurement), which does not pose imminent physical risk to patient or user.
- (b) Benefit-risk ratio is considered acceptable. Bed scales are an important option for measuring patients. Usage of device is unlikely to result in harm to user or patient.

General Handling

- Device should be placed on stable, flat, solid, non-slippery surface.
- Usage on soft surfaces (ex: carpet) may result in inaccurate results.
- Ensure all parts are properly locked and tightened before operating the device.
- Device is intended to measure one subject at a time.

Safety Instructions

Before putting device into use, please read this user manual carefully. It contains important instructions for installation, usage, and maintenance of device.

The manufacturer shall not be liable for damages caused by failure to heed the following instructions:

- Batteries should be kept away from children. If swallowed, promptly seek medical assistance.
- Expected service life: 5 years.
- Always comply with appropriate regulations when using electrical components under increased safety requirements.
- Improper installation will render the warranty null and void.
- Ensure voltage marked on power supply matches mains power supply.
- The device is intended for indoor use only.
- Observe permissible ambient temperatures for use
- Device meets requirements for electromagnetic compatibility. Do not exceed the maximum values specified in the applicable standards.

Environmental

- All batteries contain toxic compounds; batteries should be disposed of via designated competent organizations. Batteries should not be incinerated.

Cleaning

- Device surface should be cleaned using alcohol-based wipes. Corrosive cleansing liquids should not be used. Pressure-washers should not be used.
- Do not use large amounts of water when cleaning the device, as it may cause damage to the internal electronics.
- Always disconnect device from mains power before cleaning.

Maintenance

- Please contact your local Charder distributor for regular maintenance and calibration, regular checking of accuracy is recommended; frequency to be determined by level of use and state of device.

Warranty/Liability

- If Charder is responsible for a fault or defect present upon receipt of the unit, Charder shall either repair the fault, or supply a replacement unit. Should the repairs or replacement delivery fail, statutory provisions shall be valid. The period of warranty shall be two years, beginning on the date of purchase. Please retain your receipt as proof of purchase.
- No responsibility shall be accepted for damage caused through any of the following reasons: unsuitable or improper storage or use, incorrect installation or commissioning by the owner or

third parties, natural wear and tear, changes or modifications, incorrect or negligent handling, chemical, electrochemical, or electrical interference, unless damage is attributable to negligence on the part of Charder.

- This device does not contain any user-maintained parts. All maintenance, technical inspections, and repairs should be conducted by an authorized Charder service partner, using original Charder accessories and spare parts. Charder is not liable for any damages arising from improper maintenance or usage. Dismantlement of the device will void the warranty.

Disposal

- This product is not to be treated as regular household waste, but should be taken to a designated collection points for electronics. Further information should be provided by local waste disposal authorities.



Warning

- Only the original adapter should be used with the device. Using an adapter other than the one provided by Charder may cause malfunction.
- Do not touch the power supply with wet hands.
- Do not crimp the power cable, and avoid sharp edges.
- Do not overload extension cables connected to the device.
- Route cables carefully, to avoid tripping.
- Keep device away from liquids.
- Do not remove the plug by yanking on the cable.
- Use only a correctly wired (100-240V AC) outlet, and do not use a multiple outlet extension cable.
- Do not under any circumstances dismantle or alter the device, as this could result in electric shock or injury as well as adversely affect the precision of measurements.
- Do not place the device in direct sunlight, or in close proximity to an intense heat source. Excessively high temperatures may damage the internal electronics.

Incident Reporting

- Any serious incident that has occurred in relation to the device should be reported to the manufacturer, EU representative (if device is used in EU member state), and competent authority of user/subject's member state.

B. EMC Guidance and Manufacturer's Declaration

| Guidance and manufacturer's declaration-electromagnetic emissions | | |
|---|-------------------|---|
| The product is intended for use in the electromagnetic environment specified below. The customer or the user of the product should assure that it is used in such an environment. | | |
| Emission test | Compliance | Electromagnetic environment-guidance |
| RF emissions CISPR 11 | Group 1 | The product uses RF energy only for its internal function. Therefore, its RF emissions are very low and are not likely to cause any interference in nearby electronic equipment. |
| RF emissions CISPR 11 | Class A | The product is suitable for use in all establishments other than domestic and those directly connected to a low voltage power supply network which supplies buildings used for domestic purposes. |
| Harmonic emissions IEC 61000-3-2 | Class A | |
| Voltage fluctuations /flicker emissions IEC 61000-3-3 | Compliance | |

Guidance and manufacturer's declaration-electromagnetic immunity

The product is intended for use in the electromagnetic environment specified below. The customer or the user of the product should assure that it is used in such an environment.

| Immunity test | IEC 60601 test level | Compliance level | Electromagnetic environment-guidance |
|---|---|---|--|
| Electrostatic discharge(ESD) IEC 61000-4-2 | <u>±8 kV contact</u> <u>±2 kV, ±4 kV, ±8 kV, ±15 kV air</u> | <u>±8 kV contact</u> <u>±2 kV, ±4 kV, ±8 kV, ±15 kV air</u> | Floors should be wood, concrete or ceramic tile. If floors are covered with synthetic material, the relative humidity should be at least 30% |
| Electrical fast transient/burst IEC 61000-4-4 | <u>± 2kV for power supply lines</u> | <u>± 2kV for power supply lines</u> | Mains power quality should be that of a typical commercial or hospital environment. |
| Surge IEC 61000-4-5 | <u>± 1kV line(s) to line(s)</u> <u>± 2kV line(s) to earth</u> | <u>± 1kV line(s) to line(s)</u> <u>± 2kV line(s) to earth</u> | Mains power quality should be that of a typical commercial or hospital environment. |
| Voltage Dips, short interruptions and voltage variations on power supply input lines IEC 61000-4-11 | <u>0% UT for 0,5 cycle</u> <u>0% UT for 1 cycle</u> <u>70% UT(30% dip in UT) for 25cycles</u> <u>0% UT for 5 s</u> | <u>0% UT for 0,5 cycle</u> <u>0% UT for 1 cycle</u> <u>70% UT(30% dip in UT) for 25cycles</u> <u>0% UT for 5 s</u> | Mains power quality should be that of a typical commercial or hospital environment. If the user of the product requires continued operation during power mains interruptions, it is recommended that the product be powered from an uninterruptible power supply or a battery. |
| Power frequency (50, 60 Hz) magnetic field IEC 61000-4-8 | 30 A/m | 30 A/m | The product power frequency magnetic fields should be at levels characteristic of a typical location in a typical commercial or hospital environment. |
| NOTE UT is the a.c. mains voltage prior to application of the test level. | | | |

Guidance and manufacturer's declaration-electromagnetic immunity

The product is intended for use in the electromagnetic environment specified below.

The customer or the user of the product should assure that is used in such and environment.

| Immunity test | IEC 60601 test level | Compliance level | Electromagnetic environment-guidance |
|----------------------------------|---|---|--|
| Conducted RF IEC 61000-4-6 | 3 Vrms 150 KHz to 80 MHz <u>6 V in ISM bands between 0,15 MHz and 80 MHz</u> <u>80 % AM at 1 kHz</u> | 3 Vrms 150 KHz to 80 MHz <u>6 V in ISM bands between 0,15 MHz and 80 MHz</u> <u>80 % AM at 1 kHz</u> | Portable and mobile RF communications equipment should be used no closer to any part of the product including cables, than the recommended separation distance calculated from the equation applicable to the frequency of the transmitter. Recommended separation distance: $d = 1,2 \sqrt{P}$ $d = 2,3 \sqrt{P}$ 80MHz to 800 MHz $d = 2,3 \sqrt{P}$ 800MHz to 2,7GHz Where P is the maximum output power rating of the transmitter in watts (W) according to the transmitter manufacturer and d is the recommended separation distance in metres (m). Field strengths from fixed RF transmitters, as determined by an electromagnetic site survey, ^a should be less than the compliance level in each frequency range. ^b Interference may occur in the vicinity of equipment marked with the following symbol:  |
| Radiated RF IEC 61000-4-3 | 3 V/m <u>80MHz to 2,7 GHz</u> | 3 V/m <u>80MHz to 2,7 GHz</u> | |

NOTE1 At 80 MHz and 800 MHz, the higher frequency range applies.

NOTE2 These guidelines may not apply in all situations. Electromagnetic propagation is affected by absorption and reflection from structures, objects and people.

- a Field strengths from fixed transmitters, such as base stations for radio (cellular/cordless) telephones and land mobile radios, amateur radio, AM and FM radio broadcast and TV broadcast cannot be predicted theoretically with accuracy. To assess the electromagnetic environment due to fixed RF transmitters, an electromagnetic site survey should be considered. If the measured field strength in the location in which the product is used exceeds the applicable RF compliance level above, the product should be observed to verify normal operation. If abnormal performance is observed, additional measures may be necessary, such as re-orienting or relocating the product.
- b Over the frequency range 150 kHz to 80 MHz, field strengths should be less than 3V/m.

Recommended separation distance between portable and mobile RF communications equipment and the product

The product is intended for use in an electromagnetic environment in which radiated RF disturbances are controlled. The customer or the user of the product can help prevent electromagnetic interference by maintaining a minimum distance between portable and mobile RF communications equipment (transmitters) and the product as recommended below, according to the maximum output power of the communications equipment.

| Rated maximum output power of transmitter W | Separation distance according to frequency of transmitter m | | |
|--|--|--|---|
| | 150 kHz to 80 MHz $d = 1,2\sqrt{P}$ | 80 MHz to 800 MHz $d = 1,2\sqrt{P}$ | 800 MHz to 2,7 GHz $d = 2,3\sqrt{P}$ |
| 0,01 | 0.12 | 0.12 | 0.23 |
| 0,1 | 0.38 | 0.38 | 0.73 |
| 1 | 1.2 | 1.2 | 2.3 |
| 10 | 3.8 | 3.8 | 7.3 |
| 100 | 12 | 12 | 23 |

For transmitters rated at a maximum output power not listed above, the recommended separation distance d in metres (m) can be estimated using the equation applicable to the frequency of the transmitter, where p is the maximum output power rating of the transmitter in watts (W) according to the transmitter manufacturer.

NOTE1 At 80 MHz and 800 MHz, the separation distance for the higher frequency range applies.

NOTE2 These guidelines may not apply in all situations. Electromagnetic propagation is affected by absorption and reflection from structures, objects and people.

IV. Installation

A. Setting up weight bridges

1. Place weight bridges under bed next to bed castors.

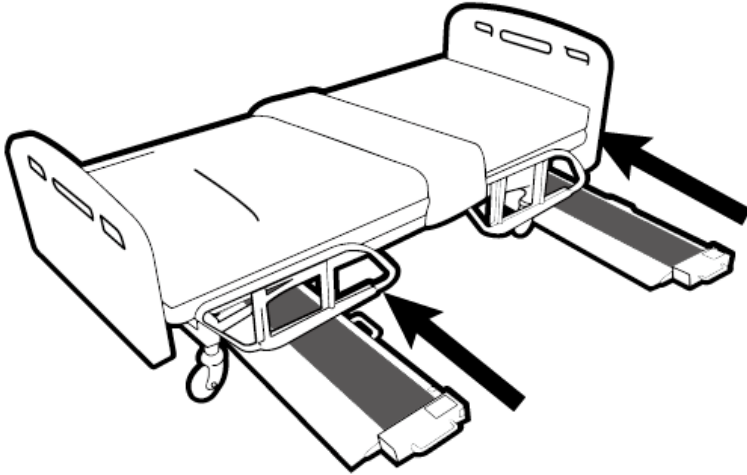

2. Device should be placed on non-slippery, flat, hard, level surface. Make sure bubble level indicator is centered to ensure result accuracy.

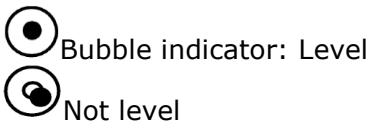

3. Connect weight bridges. All pins should be connected slowly and carefully to avoid damage.

Blue cable should be plugged into blue port; yellow cable should be plugged into yellow port.

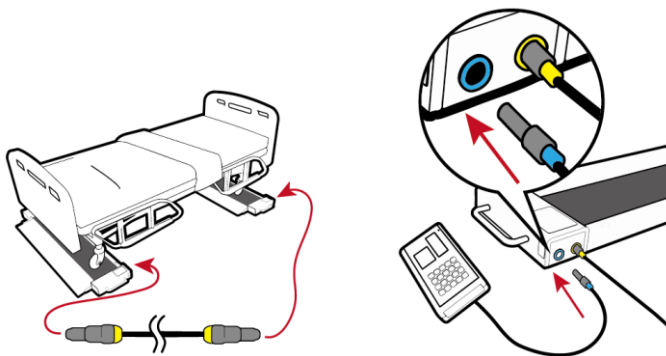

Note: connect both weight bridges to one another using weight bridge connecting wire. Connect indicator to weight bridge 2 (blue port).

4. Turn on device.

5. **After device is turned on**, push bed onto weight bridges. Two people may be needed to complete procedure.

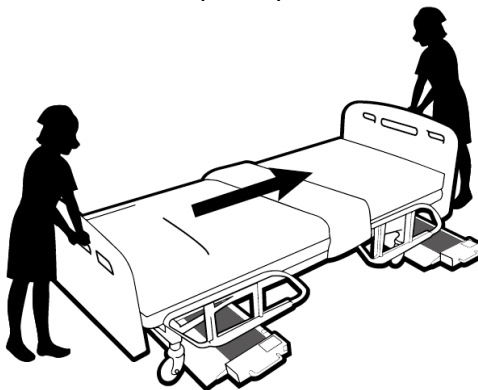

Note: take care not to catch connecting cable under platform or bed.

B. Inserting Batteries

1 · Open battery housing cover

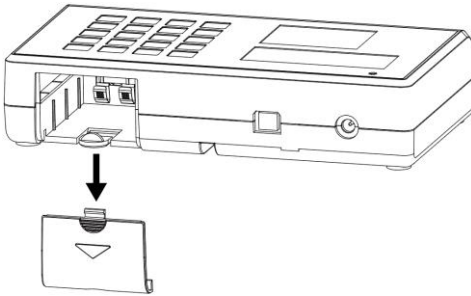

2 · Take out the battery housing

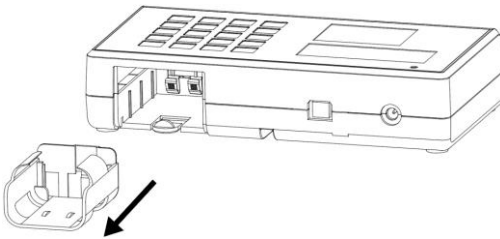

3 · Ensure batteries are installed into the housing correctly

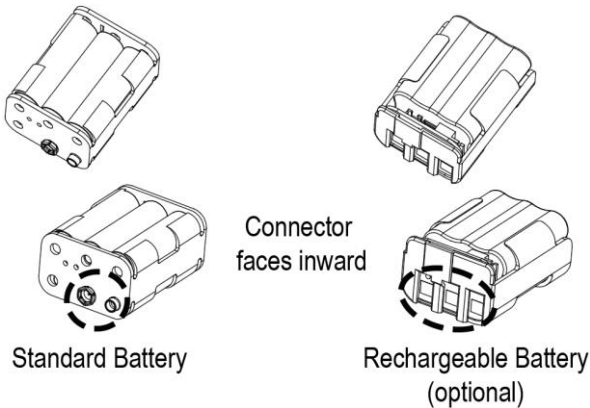

4 · Install the battery housing into the compartment, and make sure the right side of housing pin is facing towards inside of the connecting position

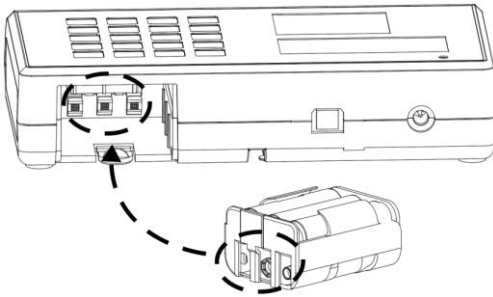

5 · Slide back the cover to close the battery housing compartment. Turn on power to confirm that battery is correctly installed.

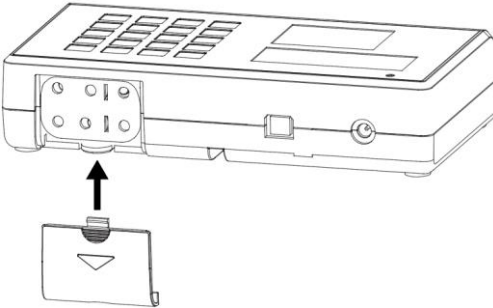

Using Rechargeable Battery (optional)

The rechargeable battery should be recharged at least once every 3 months, regardless of if the device has been used. Battery can be charged by plugging device's exclusive adapter into AC Connector Port.

After a long period in storage (e.g. >3 months), the battery should run a full cycle (charge/discharge) to allow it to restore full capacity.

Ensure rechargeable battery housing is installed and inserted properly into the compartment.

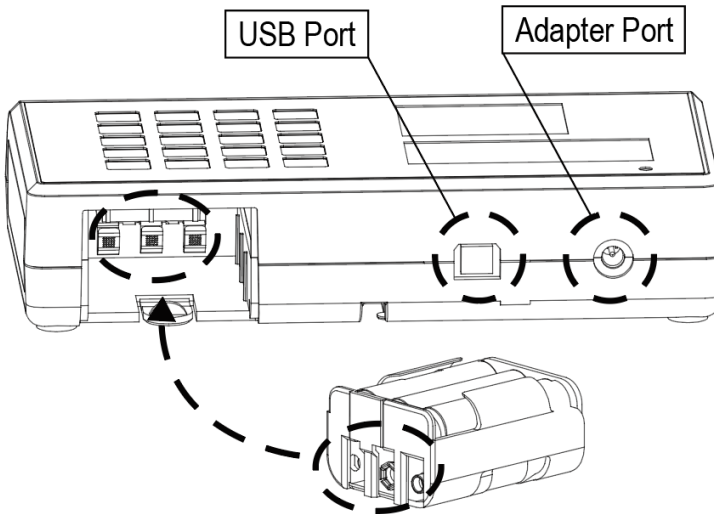

If Lo prompt displays on the LCD, please charge battery promptly to avoid battery damage.

V. Indicator

A. Indicator and Key Functions



Key Function

| | |
|----------------|--|
| ON/OFF | Power on or power off. |
| ZERO | Reset display to 0.0 kg display (can be used if within $\pm 2\%$ of full capacity). Press and hold for 3 seconds to enter device settings. |
| M1-10 | Save pre-tare values (up to 10) |
| PRE-TARE | Pre-tare the known weight of an object (ex: clothing) before beginning measurement. |
| PRINT | When printer or PC is connected to the scale, press this key to print results |
| MONITOR WEIGHT | Track change in patient weight |
| ALARM | Turn weight change alarm on/off, adjust volume of alarm |
| HOLD/BMI | Determine stable weighing value - used when weight is unstable. Press and hold for 3 seconds to enter BMI mode. |
| 0-9 | For entering digits. |
| CLEAR | Clear incorrect data input. |
| ENTER | Confirm input. |

B. Display layout

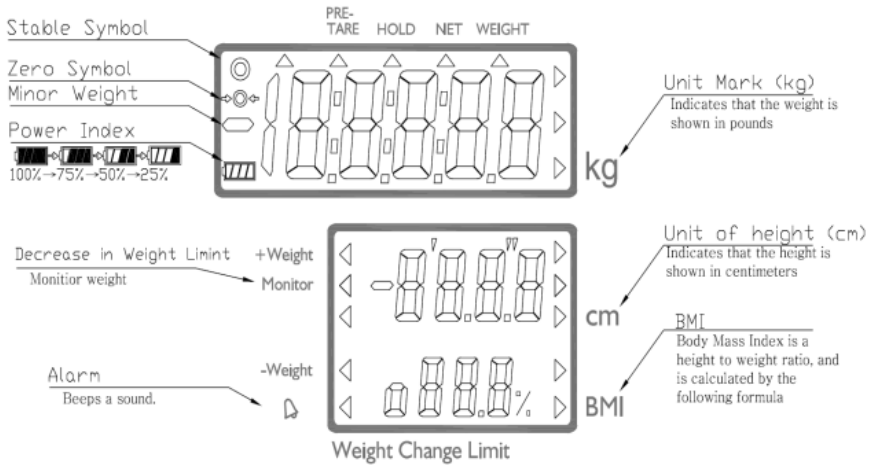

Definitions

Stable symbol: Indicates that weight is stable.

Zero symbol: Weight is at zero

Minor weight: Weight under zero.

Low battery: Battery needs to be charged or replaced.

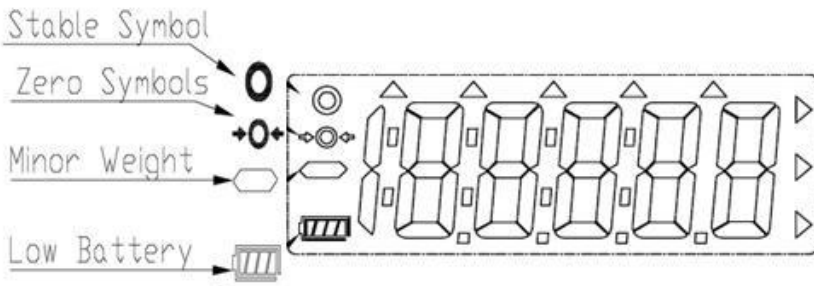

VI. Using Device

A. Performing measurement

Install weight bridges under the bed and connect all wires.

Switch on the device using **[ON/OFF]** key. The device will automatically perform self-calibration, displaying software version. Once "0.00 kg" appears on indicator, device is ready for measurement.

Note: If "0.00 kg" does not display on indicator, press **[ZERO]** key to zero the device. This function can be used for weight within $\pm 2\%$ of full capacity.

User can either select pre-tare bed weight, or deduct weight of bed at point of measurement.

Using pre-tare bed weight (used when subject is already in bed):

1. Recall previously stored Pre-Tare value (bed weight) from device memory by pressing and holding **[M1-10]** key for 3 seconds. Indicator will display pre-tare value M1 first. The pre-tare value will flash.

2. Press numeral keys 0~9 to select pre-tare value. Press **[ENTER]** key to confirm selection.

(for instructions on how to set Pre-Tare, please refer to **Setting and Recalling Pre-Tare**.)

Scale will deduct weight of bed, and minus (-) sign will appear in front of Pre-Tare value.

3. Push bed (with subject) onto weight bridges. Conduct measurement.

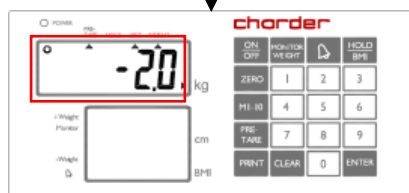
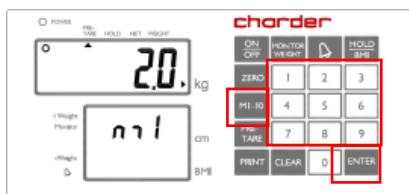

Deduct weight of bed at point of measurement:

1. Push bed (without subject) onto weight bridges.

2. Press **[PRE-TARE]** key after stable symbol appears on indicator. Display will indicate "0.00 kg".

3. Guide subject to lie down upon bed. Conduct measurement.

4. To clear tare value, remove bed from weight bridges, and press **[PRE-TARE]** key.



Note: If total weight exceeds scale capacity (600 kg, including tare), indicator will display "Err" prompt due to overload.

If subject's weight has difficulty stabilizing, the Hold function can be used.

B. Hold

The hold function determines average weight, designed to be used if subject's weight will not stabilize (ex: an active child).

Note: if fluctuation is too severe, average weight determination will be difficult and hold may not function correctly

1. After recalling pre-tare weight (bed weight) from memory, scale will deduct bed weight and (-) will appear in front of weight.

2. Push bed onto weight bridges.

3. Press the **[HOLD]** key. "HOLD" will be displayed on the indicator.



4. After a few seconds, the average weight will be displayed on the indicator.

5. To release the locked weight, press the **[HOLD]** key again to return to the device to normal mode.

Note: Hold function can be activated before or after bed is pushed onto weight bridges. If subject is unstable, we recommend pressing using Hold after the bed has been pushed onto weight bridges.

C. BMI

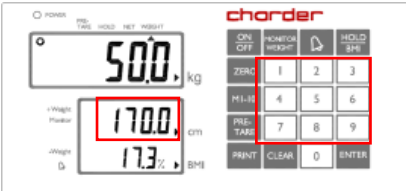
After weight has been measured, BMI can be calculated.

| | |
|--|---|
| <p>1. Without removing bed from weight bridges, press and hold the [HOLD/BMI] key for 3 seconds to enter BMI mode.</p> |  |
| <p>Display will show last recorded height. Left-most digit will flash.</p> <p>2. Enter height using numeral keys (ex: 170 cm). Input will automatically move to next digit.</p> <p>Press [CLEAR] key to re-input.</p> |  |
| <p>After inputting height, press [ENTER] to confirm.</p> |  |
| <p>Device will display subject's BMI automatically.</p> |  |

| Category | BMI (kg/m ²) | Risk of obesity-related disease |
|-----------|--------------------------|---------------------------------|
| Under | < 18.5 | Low |
| Normal | 18.5-24.9 | Average |
| Over | 24.9-29.9 | Slightly Increased |
| Obese I | 30.0-34.9 | Increased |
| Obese II | 35.0-39.9 | High |
| Obese III | > 40 | Very High |

(World Health Organization adult BMI standards)



VII. Advanced Operation

A. Pre-Tare

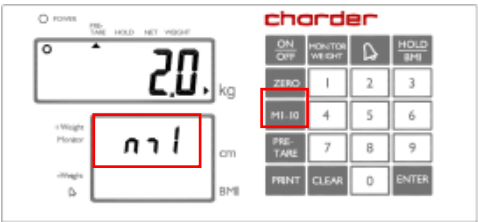
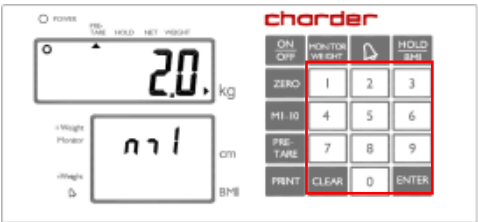

The Pre-Tare function is used to subtract the known weight of a substance prior to weighing. The MS6000 can store 10 sets of pre-tare values. Pre-tare values can be stored using two different methods: "Load Weight", or "Input Manually".

After pre-tare weights have been stored, they can be recalled by holding the **[PRE-TARE]** key for 3 seconds.

1. Load Weight

| DESCRIPTION | EXAMPLE |
|--|---|
| <p>Press M1-10 key after loading weight on the platform; the indicator will display blinking "m" symbol.</p> |  |
| <p>Press numeral key 0 ~ 9 to assign this number with the current pre-tare weight.</p> |  |
| <p>Press [ENTER] key to store pre-tare weight; the indicator will make a beep sound.</p> |  |

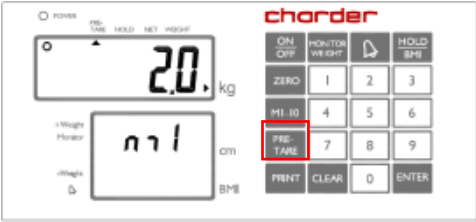
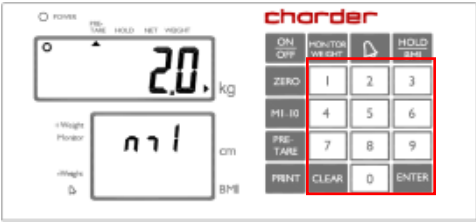
2. Input Manually

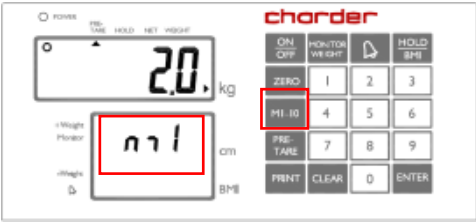
| DESCRIPTION | EXAMPLE |
|---|---|
| <p>Press and hold [PRE-TARE] key for 3 seconds. Left-most digit will begin blinking.</p> <p>If no further action is taken within 6 seconds, indicator will return to normal mode</p> |  |
| <p>While digit is blinking:</p> <p>Enter pre-tare weight using 0~9 keys.</p> <p>Ex: to pre-tare 5.0 kg of weight, press 0-0-5-0.</p> <p>Ex: to pre-tare 13.5 kg of weight, press 0-1-3-5.</p> <p>Press [ENTER] key to confirm the pre-tare weight.</p> |  |
| <p>Indicator will display minus sign to the left of pre-tare weight value.</p> |  |
| <p>To save this pre-tare weight value in memory:</p> <p>Press M1-10 key; the blinking "m" symbol will appear on the display.</p> |  |

Press numeral key 0 ~ 9 to assign this number with the current pre-tare weight.

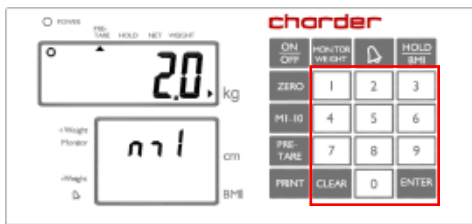



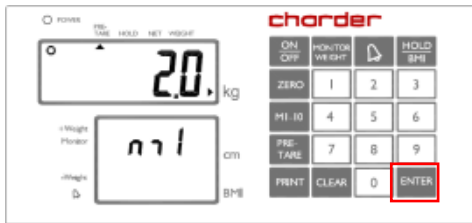

Press **[ENTER]** key to store pre-tare weight; the indicator will make a beep sound.

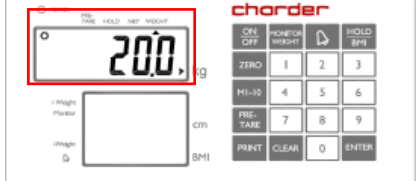

NOTE: Pre-tare weight must be under max capacity, otherwise screen will show 0.00 after **[ENTER]** key is pressed, and the operator will have to re-input pre-tare settings.

B. Weight Tracking & Alarm

Prepare bed; place pillows, blankets, and any other objects affecting weight onto bed. Turn on device before pushing bed onto weight bridges.

| | |
|--|---|
| <p>After bed has been pushed onto weight bridges, display will show total bed weight on upper LCD.</p> |  |
| <p>Press Pre-Tare key to tare the weight of the bed, the scale will return to "0.0 kg" reading.</p> |  |
| <p>Guide subject to lie upon bed. Display now shows net weight of subject. (*)</p> |  |
| <p>Press and hold MONITOR WEIGHT key; the subject's weight will lock, and the middle display will display "0.0".</p> <p>Arrow will point to "+ weight".</p> |  |
| <p>Use numeral keys 0~9 to set the increase in weight limit and press ENTER key.</p> |  |

The lower display will begin blinking, pointing to the (-) weight limit. (**).

Use numeral keys 0~9 to set the decrease in weight limit. The minus (-) sign will appear in front of the weight decrease value.

After setting the weight decrease value, press the **ENTER** key. (**).

Indicator will return to "0.0".

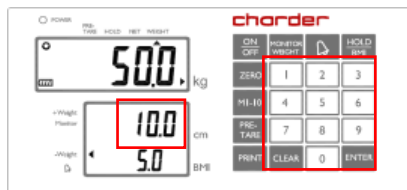

Press **MONITOR WEIGHT** key to turn on the alarm.

The blinking arrow pointing to



sign means the Alarm volume is at maximum. To decrease volume level, press



key again, and the blinking arrow will stop blinking.

To turn off the alarm, press the



key until the arrow disappears.











***NOTE-** If the Weight Tracking Function is activated, the original subject's weight will be saved in memory. This function can be activated only after the bed has been pushed onto the weight bridges, and the subject is lying down on the bed.

****NOTE-** The weight change range starts from 500g/- 500g, and can be increased/ decreased by increments of 100g.

VIII. Device Setup

A. Setting Time & Date

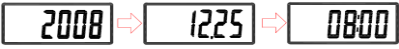
Press and hold  key for 3 seconds to enter Time Setting mode.
Example: Inputting 2008, Dec 25, 8:00am

| | |
|---|--|
|  | <p>Year Setting Enter year using numeral keys 0-9. Press  key once completed to proceed to month & day setting.</p> |
|  | <p>Month & Day Setting. Enter month, followed by day using numeral keys 0-9. Ex: December 25th is "12.25". Input 1-2-2-5. Press  key once completed to proceed to time setting.</p> |
|  | <p>Time Setting Enter time (24hr format) using numeral keys 0-9. Ex: 08:00am is input by pressing 0-8-0-0. Press  key once completed to confirm time settings and proceed to confirmation.</p> |
|  | <p>Device will display new time and date settings, cycling between year, month & day, and time. YYYY→MM.DD→:HH:MM Press  key to return to normal weighing mode.</p> |

B. Device Setup

When the device is switched on, press and hold the **[ZERO]** key for about 3 seconds, until the display shows the "SETUP", followed by "A.OFF" (first option in setting menu).

In device setup:

[PRE-TARE] to toggle next menu option

[ZERO] to toggle previous menu option

[HOLD/BMI] to confirm selection

A digital display showing the text "A.OFF" in a segmented font.

Auto Power-Off: Instruct device to shut off automatically after a certain period of time.

Auto off options: 120 sec / 180 sec / 240 sec / 300 sec / off

Press **[HOLD/BMI]** to toggle between time options, and **[PRE-TARE]** to confirm selection.

A digital display showing the text "bUrr" in a segmented font.

Buzzer/Beep:

When function is turned on, beeping noise will be made when: indicator is turned on, keys are pressed, and weight is stable.

Press **[HOLD/BMI]** to toggle between on/off, and **[PRE-TARE]** key to confirm selection.

A digital display showing the text "HoldS" in a segmented font.

Hold Stop: When Hold Stop is "on", Hold will deactivate after subject leaves measurement platform.

Press **[HOLD/BMI]** to toggle between on/off, and **[PRE-TARE]** key to confirm selection

A digital display showing the text "bLUE" in a segmented font.

Bluetooth (optional): If device has Bluetooth module installed, Bluetooth function can be turned on or off.

Press [**HOLD/BMI**] to toggle between on/off, and [**PRE-TARE**] to confirm selection.

An LCD display showing the text 'Wi-Fi' in a simple, pixelated font. The characters are white on a dark background.

Wi-Fi (optional): If device has Wi-Fi module installed, Wi-Fi function can be turned on or off.

Press [**HOLD/BMI**] to toggle between on/off, and [**PRE-TARE**] to confirm selection.

An LCD display showing the text 'Wi-Fi Setting' in a simple, pixelated font. The characters are white on a dark background.

Wi-Fi Setting (optional): If device has Wi-Fi module installed, this option will appear.

Press [**HOLD/BMI**] to toggle between "Auto" and "PKEY". Press [**PRE-TARE**] to confirm selection.

If "Auto" is selected, weight measurement will be automatically sent to connected printer or device. If "PKEY" is selected, transfer will occur manually only after [**PRINT**] key is pressed.

IX. Setup USB Connection to PC

For successful connection, PC hardware connected to device must be compatible with USB 2.0 or above. Operators should select a USB cable length that is most suitable to the operating environment.

1. Charder Smart Data Manager can be used to connect the device to a PC. The software program can be downloaded from the Charder website:

[LINK URL] <https://www.chardermedical.com/download.htm>

2. Connect USB cable to device indicator and PC. Follow installation instructions.

Program Setup

1. After installation of Charder Smart Data Manager is complete, software will automatically search for COM port. Press [**Connect**]. Once connected, [**Connect**] button will change to [**Disconnect**].

charder Smart Data Manager COM [▼] [Connect]

| | | | | |
|--------------|-----|----|---------------|----------------|
| Gross Weight | 0.0 | kg | First Name | Enter |
| Tare Weight | 0.0 | kg | Last Name | Enter |
| Net Weight | 0.0 | kg | Patient ID | Enter |
| Height | 0.0 | cm | Date of Birth | 31 / 12 / 1990 |
| BMI | 0.0 | | Gender | Male Female |

Data [Auto] [Manual]

Please press "Connect".
Update Time:
Model:

[Collect] [Clear] [Save as]

Icons: [Globe] [Mail] [Printer] [Help]

Conducting Measurement

1. Input subject's first name, last name, patient ID, date of birth (DD/MM/YYYY), gender, and height (for BMI calculation) into software if needed. Press **[Clear]** to clear all input.

NOTE: information can also be input after weight measurement.

The screenshot shows the Chorder Smart Data Manager interface. The top bar includes the Chorder logo, the text "Smart Data Manager", a "COM" dropdown menu, a "Connect" button, and window control icons. The main area is divided into two columns. The left column contains weight measurement fields: "Gross Weight" (0.0 kg), "Tare Weight" (0.0 kg), "Net Weight" (0.0 kg), "Height" (167.0 cm), and "BMI" (0.0). The right column contains patient information fields: "First Name" (Jane), "Last Name" (Doe), "Patient ID" (20190201), "Date of Birth" (31 / 12 / 1965), and "Gender" (Male/Female). Below these fields are "Auto" and "Manual" buttons. At the bottom, there is a status area with the text "Please press 'Connect':", "Update Time:", and "Model:". On the right side of the bottom area are "Collect", "Clear", and "Save as" buttons, along with icons for globe, mail, printer, and help.

2. Conduct measurement. If **[Auto]** is selected, results will be transmitted from device to software automatically and displayed on the left of screen. If **[Manual]** is selected, user must press "Collect".

The screenshot shows the Chorder Smart Data Manager interface after a measurement. The top bar now shows "COM 5" and a "Disconnect" button. The left column displays the results: "Gross Weight" (72.5 kg), "Tare Weight" (0.0 kg), "Net Weight" (72.5 kg), "Height" (167.0 cm), and "BMI" (26.0). The right column shows the same patient information as in the previous screenshot. The "Auto" button is now selected. The status area at the bottom left shows a cable icon, the text "Data updated.", "Update Time: 06/03/2020 11:40:05", and "Model:". The "Collect", "Clear", and "Save as" buttons are still present on the right.

Saving & Printing Results

1. Press **[Save as]** to save measurement results as .csv file on PC. Default file name is same as user ID. (ex: 20190201.csv) To track changes and multiple measurements for the same subject, we recommend not changing the default file name.

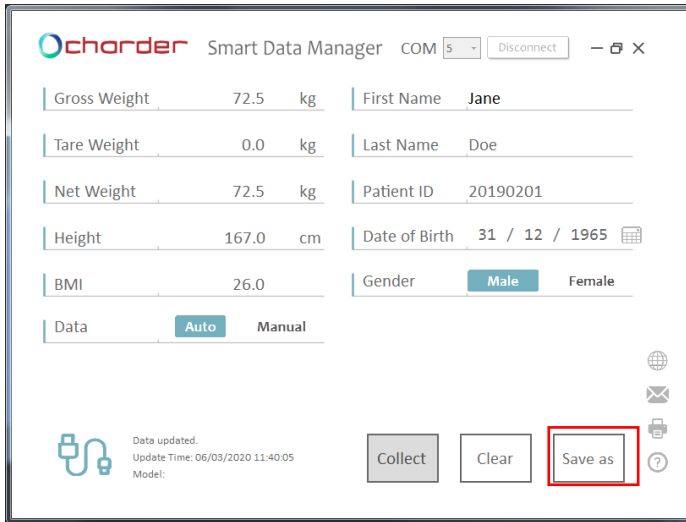

2. Result example:

| | A | B | C | D | E | F | G | H | I | J |
|---|------------|------------|-----------|------------|--------|------------|-------------|------------|----------|-----|
| 1 | Patient ID | First Name | Last Name | Date of Bi | Gender | Gross Weig | Tare Weight | Net Weight | Height | BMI |
| 2 | 20190201 | Jane | Doe | 31/12/1965 | Male | 72.4 kg | 0.0 kg | 72.4 kg | 167.0 cm | 26 |
| 3 | | | | | | | | | | |
| 4 | | | | | | | | | | |
| 5 | | | | | | | | | | |

If previous results were saved in "20190201.csv", new results also need to be saved as "20190201.csv" (overwriting old file) in order to save multiple results for the same subject.

| | A | B | C | D | E | F | G | H | I | J |
|---|------------|------------|-----------|------------|--------|------------|-------------|------------|----------|-----|
| 1 | Patient ID | First Name | Last Name | Date of Bi | Gender | Gross Weig | Tare Weight | Net Weight | Height | BMI |
| 2 | 20190201 | Jane | Doe | 31/12/1965 | Male | 72.4 kg | 0.0 kg | 72.4 kg | 167.0 cm | 26 |
| 3 | 20190201 | Jane | Doe | 31/12/1965 | Male | 75.2 kg | 0.0 kg | 75.2 kg | 167.0 cm | 27 |
| 4 | | | | | | | | | | |

Results will be saved in chronological order of measurement.

3. Press the printer icon to print out result using a printer connected to the PC.

| | | | |
|--------------|----------|---------------|--|
| Gross Weight | 72.5 kg | First Name | Jane |
| Tare Weight | 0.0 kg | Last Name | Doe |
| Net Weight | 72.5 kg | Patient ID | 20190201 |
| Height | 167.0 cm | Date of Birth | 31 / 12 / 1965 |
| BMI | 26.0 | Gender | <input checked="" type="radio"/> Male <input type="radio"/> Female |

Data

Data updated.
Update Time: 06/03/2020 11:40:05
Model:



```
Patient ID : 20190201
First Name : Jane
Last Name : Doe
Date of Birth : 31/12/1965
Gender : Male
Gross Weight : 75.2 kg
Tare Weight : 0.0 kg
Net Weight : 75.2 kg
Height : 167.0 cm
BMI : 27.0
```

X. Wireless Connection

If the device has the wireless or bluetooth module installed, the indicator can transmit measurement results wirelessly. Please see Charder wireless or bluetooth software instructions for details.

XI. Troubleshooting

Product Defects

Charder's warranty is effective for the original purchaser of this device, subject to the terms and conditions listed in the Warranty Program & Return Policy.

1. If Charder is responsible for a fault or defect present upon receipt of the unit, Charder shall either repair the fault, or supply a replacement unit. Should the repairs or replacement delivery fail, statutory provisions shall be valid. The period of warranty shall be two years, beginning on the date of purchase. Please retain your receipt as proof of purchase.

2. No responsibility shall be accepted for damage caused through any of the following reasons: unsuitable or improper storage or use, incorrect installation or commissioning by the owner or third parties, natural wear and tear, changes or modifications, incorrect or negligent handling, chemical, electrochemical, or electrical interference, unless damage is attributable to negligence on the part of Charder.

If device is not covered under warranty, a service maintenance charge will apply, plus cost of replacement parts.

Before contacting your local Charder distributor for repair service, we recommend considering the following troubleshooting procedures:

Self-inspection

1. Device will not power on

- If battery power is depleted, replace with new batteries
- If batteries are not used, check if the power adapter is plugged into the device properly. Check if power adapter is plugged into mains properly

2. Indicator showing "0000" ZERO SPAN out of range

- Interference due to factors such as RF disturbance or ground vibration. Relocate device to location without interference and try again

- Unstable platform feet - adjust level according to bubble level indicator and try again
- External objects interfering with measurement platform. Clear platform of objects and try again
- Device may not function properly on soft surfaces such as carpets or lawns. Relocate device to location with solid, stable floor
- If the steps above cannot resolve the problem, re-calibration may be required to correct weighing accuracy

3. Connection failure for data transmission to PC or printer

- Ensure wires are connected correctly between indicator and PC or printer
- Ensure printer is supplied with power. Ensure PC software is set up properly as indicated in this manual

Distributor support required

If the following errors occur, we recommend contacting your local Charder distributor for repair or replacement services:







1. Device will not power on

- Faulty on/off key
- Broken or damaged wires causing short circuit or faulty connection
- Safety fuse burnout
- Faulty Adapter

2. Indicator damage

- Possible hardware defects include: uneven brightness in LCD screen, blurred text, smeared rainbow screen, incorrect decimal display
- Unable to save or read data
- Indicator shows "ERRL" after device is switched on
- Keys not responding
- Buzzer malfunction

Error Messages

| Error Message | Reason | Action |
|---|---|--|
|  | Low battery warning Voltage of battery is too low to operate device | Replace batteries, or plug in AC adapter |
|  | Overload Total load exceeds device's maximum capacity | Reduce weight on measurement platform and try again |
|  | Counting Error (too high) Signal from loadcells too high | Error normally caused by faulty loadcell or wiring. Please contact distributor |
|  | Counting Error (too low) Signal from loadcells too low | Error normally caused by faulty loadcell or wiring. Please contact distributor |
|  | Zero count over calibration zero range +10% while power on | Re-calibration required. Please contact distributor |
|  | Zero count under calibration zero range -10% while power on | Re-calibration required. Please contact distributor |
|  | Program Error Fault with device software | Error normally caused by faulty loadcell or wiring. Please contact distributor |

XII. Product Specifications

A. Device Information

| | | |
|------------------------------|----------------------|--|
| Model | | MS6000 |
| Display | | DP3710 |
| Weight Measurement | Capacity | 300kg x 0.1kg, 300-600kg x 0.2kg |
| | Accuracy | ±1.5e |
| | OIML | Class III |
| | LCD Screen | 1.0-inch LCD screen (5 1/2 digits) |
| Dimensions | Overall | 1256(W) x 230(D) x 61(H) mm |
| | Weighing Area | 1000(W) x 160(D) |
| | Device Weight | 11.4 kg (each weighing bridge) |
| Key Functions | | On/Off, Zero, Hold/BMI, Print, Pre-Tare, Clear, Enter, M1-10, Monitor Weight, Alarm, 0~9 |
| Data Transmission | | USB, Wireless (optional) NOTE : Device should be connected to network by qualified distributors only. |
| Power Supply | | Rechargeable battery pack (optional) or 6 AA batteries / Poweradapter |
| Operation Environment | | 0°C~+40°C 15% / 85% RH 700 hPa ~1060 hPa |
| Optional Accessories | | Thermal Printer |
| Standard Accessories | | User manual x 1 Weighing bridge x 2 Connecting wire x 1 USB cable (B-type) x1 Bracket set for wall mount x1 Power Adapter x 1 |

B. Power Adapter Standards





Warning

The device is only compatible with the power adapters specified in the dashed block below.

| AMP VOLTAGE | DRAWING NO.: | CE APPROVED TYPE NO. / MODEL NO.: | TYPE | Adapter plug |
|-------------|--------------|-----------------------------------|------|--|
| 12V 2A | AD-00041 | UES24LCP-120200SPA | US |  |
| 12V 2A | AD-00041 | UES24LCP-120200SPA | EU | |
| 12V 2A | AD-00041 | UES24LCP-120200SPA | UK | |
| 12V 2A | AD-00041 | UES24LCP-120200SPA | AU | |

XIII. Declaration of Conformity

This product has been manufactured in accordance with the harmonized European standards, following the provisions of the below stated directives:

| | |
|---|--|
|  | (EU) 2017/745 Regulation on Medical Devices |
|  | 2014/31/EU Non-automatic Weighing Instruments Directive (OIML models only) |

RoHS Directive 2011/65/EU and Delegated Directive (EU) 2015/863

Radio Equipment Directive 2014/53/EU

(applicable if wireless module is used)

Part 15 of the Federal Communications Statement Rules

This device may not cause harmful interference.

This device must accept any interference received, including interference that may cause undesired operation.

Please see separate document showing on sticker of device for above markings.

Authorized EU Representative:



Obelis s.a.

Bd Général Wahis, 53
B-1030 Brussels
Belgium

Manufactured by:



Charder Electronic Co., Ltd.
No.103, Guozhong Rd., Dali Dist.,
Taichung City 41262 ,Taiwan

CD-IN-00014 REV010 08/2024