

USER MANUAL







HM100D

Infant Height Stadiometer



Please keep the instruction manual at hand all the time for future reference.

Explanation of Text/Symbols on Device Label/Packaging

Text/Symbol	Meaning
	Caution, consult accompanying documents before use
	Separate collection for waste of electrical and electronic equipment, in accordance with Directive 2002/96/EC. Do not dispose of device with everyday waste
	Name and address of device manufacturer, and year/country of manufacture
	Carefully read user manual before installation and usage, and follow instructions for use.
	Medical electrical device, Type B applied part
REF	Device catalogue number / model number
EC REP	Name and address of authorized representative in the European Union
MD	Device is a medical device. Text indicates device category type
LOT	Manufacturer's batch or lot number for device
SN	Device's serial number
UDI	Device's Unique Device Identifier
CE 2460	Device conforms to (EU) 2017/745 Regulation on Medical Devices. Four digit number is identifier for medical device Notified Body
	Name and address of entity importing device (if applicable)
A → 文	Name and address of entity responsible for translating Information For Use (if applicable)

Copyright Notice

Charder Electronic Co., Ltd.

No.103, Guozhong Rd., Dali Dist., Taichung City 41262 Taiwan

Tel: +886-4-2406 3766

Fax: +886-4-2406 5612

Website: www.chardermedical.com E-mail: info_cec@charder.com.tw

Copyright© Charder Electronic Co., Ltd. All rights reserved.

This user manual is protected by international copyright law. All content is licensed, and usage is subject to written authorization from Charder Electronic Co., Ltd. (hereinafter Charder) Charder is not liable for any damage caused by a failure to adhere to requirements stated in this manual. Charder reserves the right to correct misprints in the manual without prior notice, and modify the exterior of the device for quality purposes without customer consent.



Charder Electronic Co., Ltd.
No. 103, Guozhong Rd., Dali Dist.,
Taichung City, 41262 Taiwan

CONTENTS

I. Safety Notes	5
A. General Information	5
B. EMC Guidance and Manufacturer's Declaration	6
II. Installation	10
A. Assembly with MS3500 and MS21NEOV Infant Scale	10
B. Assembly with MS5980 Infant Scale	11
III. Using Device	13
A. Calibrating Height Stadiometer	13
IV. Product Specifications	15
A. Device Information	15
V. Declaration of Conformity	16



I. Safety Notes

A. General Information

Thank you for choosing this Charder Medical device. It is designed to be easy and straightforward to operate, but if you encounter any problems not addressed in this manual, please contact your local Charder service partner.

Before beginning operation of the device, please read this user manual carefully, and keep it in a safe place for reference. It contains important instructions regarding installation, proper usage, and maintenance.

Intended Purpose

This medical device is designed to be used in accordance with national regulations, to measure height within specifications, for height-related usage by professionals.

Clinical Benefit

Measurement results can be used by professionals to diagnose (and monitor) height-related issues.

General Handling

- Ensure all parts are properly locked and tightened before operating the device.
- Measurement accuracy requires the subject's feet, back, and head to be straightly aligned. Please note that height can vary throughout the day
- **CAUTION:** Do not use next to equipment that may cause electromagnetic or other types of interference.

Safety Instructions

Before putting device into use, please read this user manual carefully. It contains important instructions for installation, usage, and maintenance of device.

The manufacturer shall not be liable for damages caused by failure to heed the following instructions:

- The device has an expected service life of 5 years when correctly handled, serviced, and periodically inspected in accordance with manufacturer's instructions.
- Improper installation will render the warranty null and void.
- Observe permissible ambient temperatures for use

Cleaning

- Device surface should be cleaned using alcohol-based wipes.

Warranty/Liability

- The period of warranty shall be eighteen(18) months, beginning on the date of purchase. Please retain your receipt as proof of purchase.
- No responsibility shall be accepted for damage caused through any of the following reasons: unsuitable or improper storage or use, incorrect installation or commissioning by the owner or third parties, natural wear and tear, changes or modifications, incorrect or negligent handling, chemical, electrochemical, or electrical interference, unless damage is attributable to negligence on the part of Charder.
- This device does not contain any user-maintained parts. All maintenance, technical inspections, and repairs should be conducted by an authorized Charder service partner, using original Charder accessories and spare parts. Charder is not liable for any damages arising from improper maintenance or usage. Dismantlement of the device will void the warranty.

Incident Reporting

- Any serious incident that has occurred in relation to the device should be reported to the manufacturer, EU representative (if device is used in EU member state), and competent authority of user/subject's member state.

B. EMC Guidance and Manufacturer's Declaration

Guidance and manufacturer's declaration-electromagnetic emissions		
The device is intended for use in the electromagnetic environment specified below. The customer or the user of the device should assure that it is used in such an environment.		
Emission test	Compliance	Electromagnetic environment-guidance
RF emissions CISPR 11	Group 1	The device uses RF energy only for its internal function. Therefore, its RF emissions are very low and are not likely to cause any interference in nearby electronic equipment.

RF emissions CISPR 11	Class A	The product is suitable for use in all establishments other than domestic and those directly connected to a low voltage power supply network which supplies buildings used for domestic purposes.
-----------------------	---------	---

Guidance and manufacturer’s declaration-electromagnetic immunity

The device is intended for use in the electromagnetic environment specified below. The customer or the user of the device should assure that it is used in such an environment.

Immunity test	IEC 60601 test level	Compliance level	Electromagnetic environment-guidance
Electrostatic discharge(ESD) IEC 61000-4-2	<u>± 8 kV contact</u> <u>± 2 kV, ± 4 kV,</u> <u>± 8 kV, ± 15 kV</u> <u>air</u>	<u>± 8 kV contact</u> <u>± 2 kV, ± 4 kV,</u> <u>± 8 kV, ± 15 kV</u> <u>air</u>	Floors should be wood, concrete or ceramic tile. If floors are covered with synthetic material, the relative humidity should be at least 30%
Power frequency(50/60 Hz) magnetic field IEC 61000-4-8	<u>30 A/m</u>	<u>30 A/m</u>	The device power frequency magnetic fields should be at levels characteristic of a typical location in a typical commercial or hospital environment.

NOTE UT is the a.c. mains voltage prior to application of the test level.

Guidance and manufacturer's declaration-electromagnetic immunity

The device is intended for use in the electromagnetic environment specified below. The customer or the user of the device should assure that is used in such an environment.

Immunity test	IEC 60601 test level	Compliance level	Electromagnetic environment-guidance
Radiated RF IEC 61000-4-3	3 V/m 80MHz to 2,7 GHz	3 V/m <u>80MHz to 2,7 GHz</u>	<p>Recommended separation distance:</p> <p>$d = 1,2 \sqrt{P}$ $d = 1,2 \sqrt{P}$ 80MHz to 800 MHz $d = 2,3 \sqrt{P}$ 800MHz to 2,5 GHz</p> <p>Where P is the maximum output power rating of the transmitter in watts (W) according to the transmitter manufacturer and d is the recommended separation distance in metres (m).</p> <p>Field strengths from fixed RF transmitters, as determined by an electromagnetic site survey^a, should be less than the compliance level in each frequency range^b.</p> <p>Interference may occur in the vicinity of equipment marked with the following symbol:</p> <div style="text-align: center;">  </div>

NOTE1 At 80 MHz and 800 MHz, the higher frequency range applies.

NOTE2 These guidelines may not apply in all situations. Electromagnetic propagation is affected by absorption and reflection from structures, objects and people.

- a Field strengths from fixed transmitters, such as base stations for radio (cellular/cordless) telephones and land mobile radios, amateur radio, AM and FM radio broadcast and TV broadcast cannot be predicted theoretically with accuracy. To assess the electromagnetic environment due to fixed RF transmitters, an electromagnetic site survey should be considered. If the measured field strength in the location in which the device is used exceeds the applicable RF compliance level above, the device should be observed to verify normal operation. If abnormal performance is observed, additional measures may be necessary, such as re-orienting or relocating the device.
- b Over the frequency range 150 kHz to 80 MHz, field strengths should be less than 3 V/m.

Recommended separation distance between portable and mobile RF communications equipment and the Device

The device is intended for use in an electromagnetic environment in which radiated RF disturbances are controlled. The customer or the user of the device can help prevent electromagnetic interference by maintaining a minimum distance between portable and mobile RF communications equipment (transmitters) and the device as recommended below, according to the maximum output power of the communications equipment.

Rated maximum output power of transmitter W	Separation distance according to frequency of transmitter m		
	150 kHz to 80 MHz $d = 1,2\sqrt{P}$	80 MHz to 800 MHz $d = 1,2\sqrt{P}$	800 MHz to 2,7 GHz $d = 2,3\sqrt{P}$
0,01	0,12	0,12	0,23
0,1	0,38	0,38	0,73
1	1,2	1,2	2,3
10	3,8	3,8	7,3
100	12	12	23

For transmitters rated at a maximum output power not listed above, the recommended separation distance d in metres (m) can be estimated using the equation applicable to the frequency of the transmitter, where p is the maximum output power rating of the transmitter in watts (W) according to the transmitter manufacturer.

NOTE1 At 80 MHz and 800 MHz, the separation distance for the higher frequency range applies.

NOTE2 These guidelines may not apply in all situations. Electromagnetic propagation is affected by absorption and reflection from structures, objects and people.

II. Installation

A. Assembly with MS3500 and MS21NEOV Infant Scale

1. Attach bracket to tray using bracket screws*2

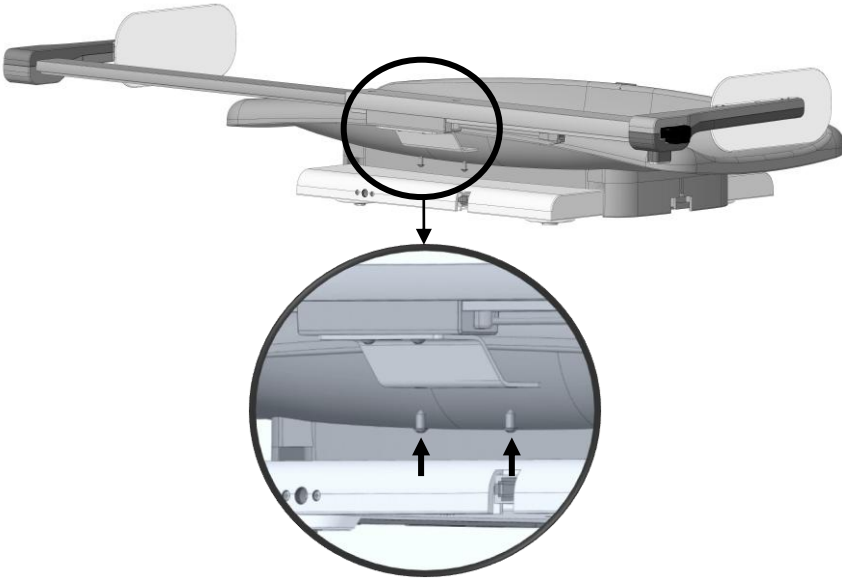

2. Connect HM100D cable to scale.

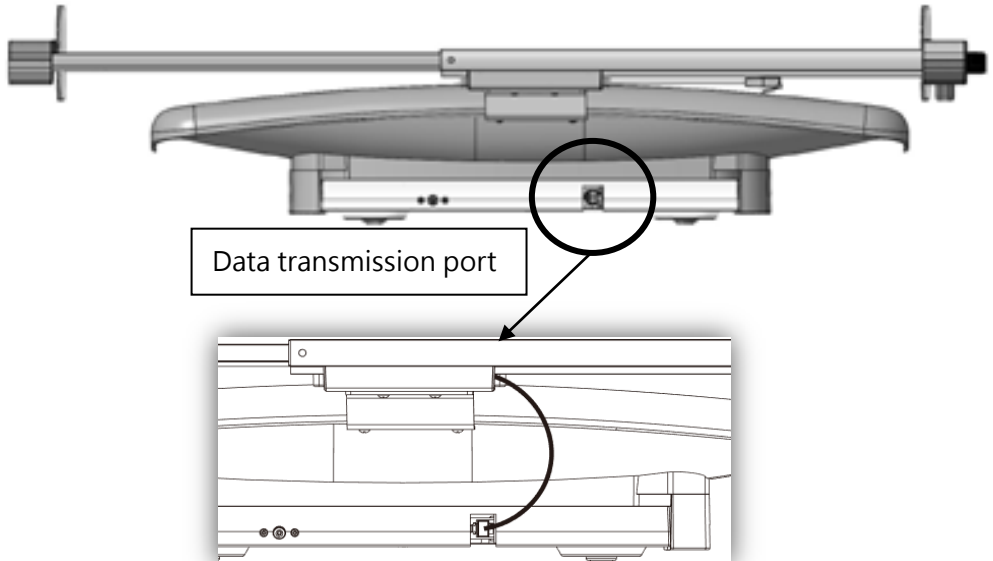

B. Assembly with MS5980 Infant Scale

1. Carefully attach head stopper to each end of height rod.
2. Install height rod + head stopper onto bracket using Philips screws.

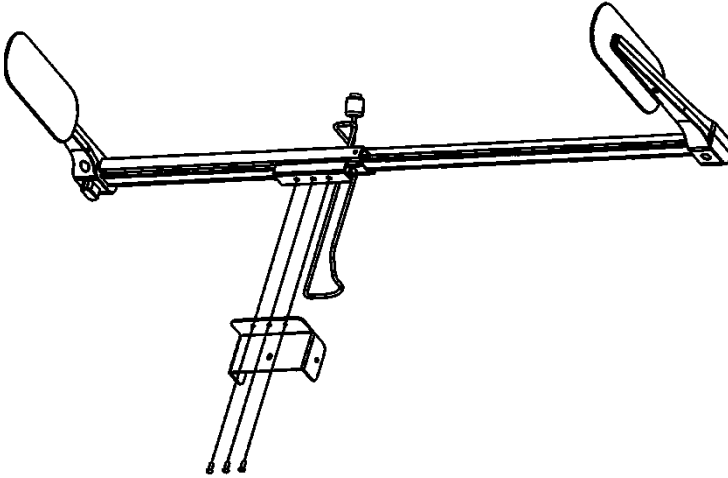

3. 4. Install height rod + head stopper + bracket onto infant scale.
(Twist knobs clockwise to secure bracket)

5. 6. Secure cable using cable ties, and plug cable into 6-pin port on indicator.

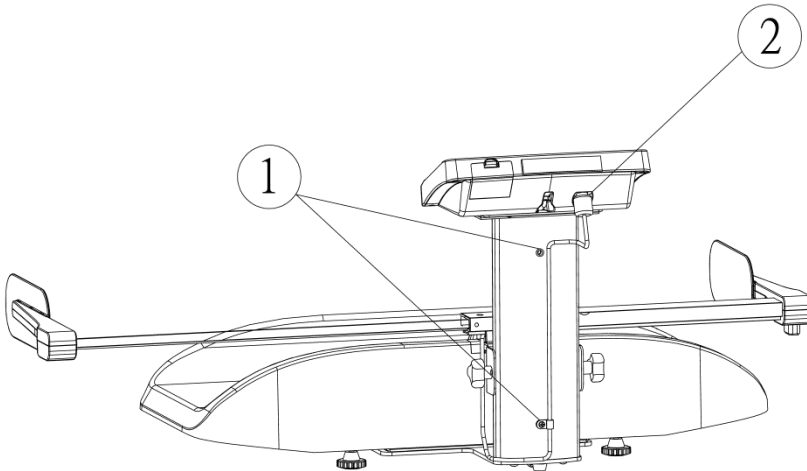

Plug data transmission port into indicator.

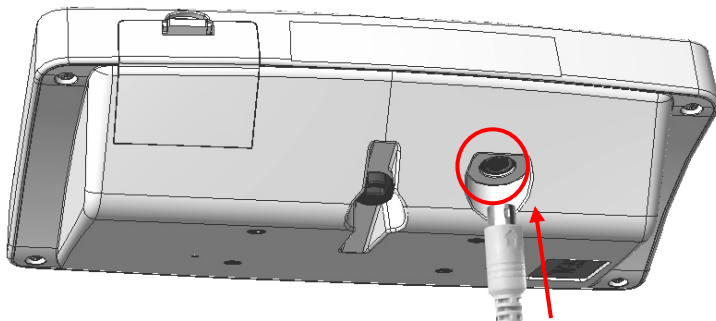

III. Using Device

A. Calibrating Height Stadiometer

Before using height stadiometer, slide measurement rod to left completely then turn on scale to finish calibration.

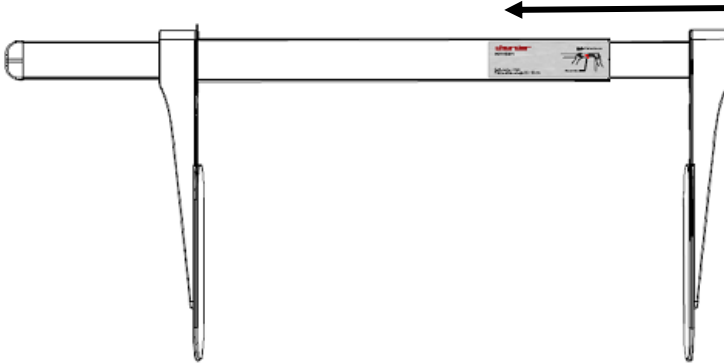

B. Performing measurement and operating

1. Lay infant on flat platform, with head touching head stopper. Straighten infant's feet.

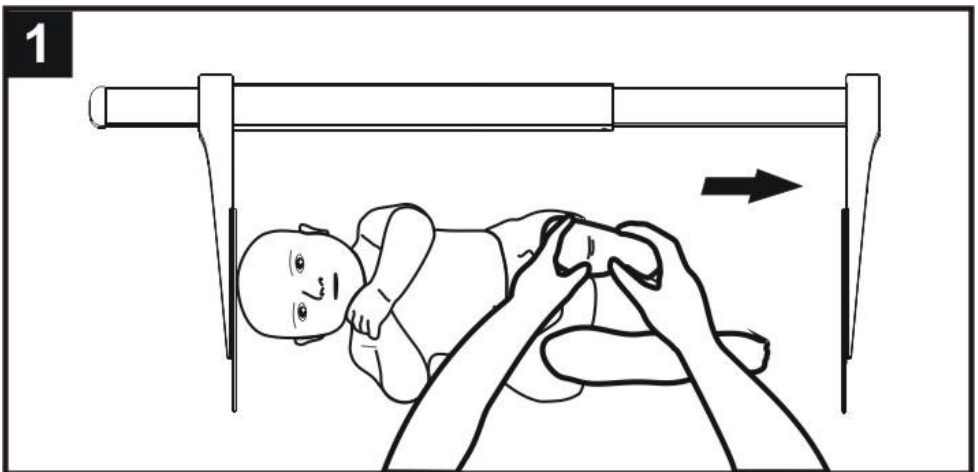

2. Use right hand to push foot stopper until it touches soles of infant's feet. You can also read measurement result from stadiometer. The height measurement result will automatically be sent to device indicator and display at the same time.

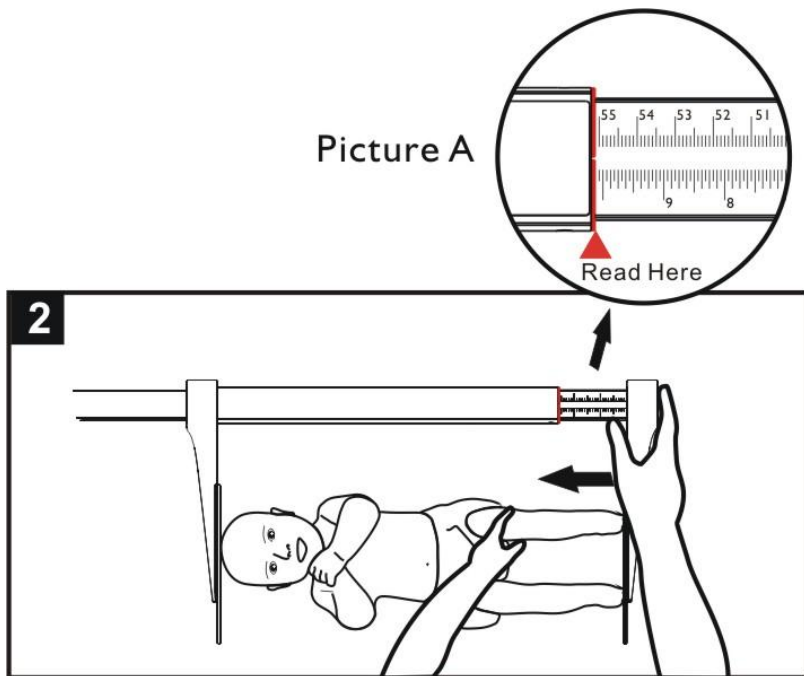

IV. Product Specifications

A. Device Information

Model		HM100D
Height Measurement	Range	35-100 cm 13 3/4-39 1/2 in
	Graduation	1 mm 1/16 in
	Accuracy	±10 mm
Dimensions	Overall	1075(W) x 287(D) x 72(H) mm
	Device Weight	0.68 kg
Power Source		AAA Batteries*2
Operation Temperature & Humidity		5°C~35°C
Standard Accessories		User manual x1
Optional Accessories		Bracket set for installation on compatible Charder Infant Scale

V. Declaration of Conformity

Manufacturer hereby declares that this product is in conformity with the regulations and standards outlined in the following directives:

	(EU) 2017/745 Regulation on Medical Devices Classification: Class I with measuring function
---	---

RoHS Directive 2011/65/EU and Delegated Directive (EU) 2015/863

Authorized EU Representative:



Obelis s.a.

Bd Général Wahis, 53
B-1030 Brussels
Belgium



Manufactured by:

Charder Electronic Co., Ltd.
No.103, Guozhong Rd., Dali Dist.,
Taichung City, 41262 Taiwan (R.O.C.)

CD-IN-00491 REV 001 2022/06